

Pure
BY TUNTURI®

English

11

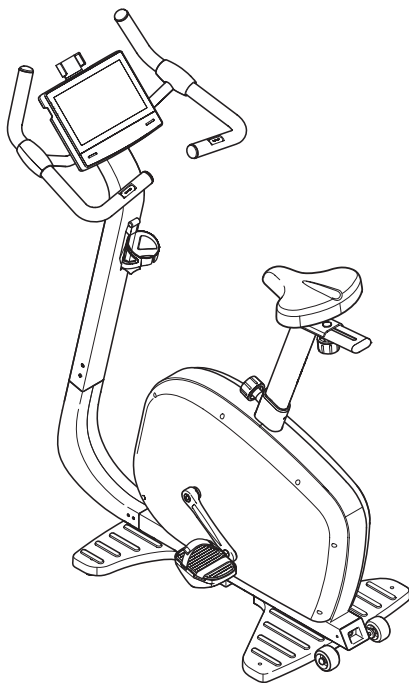

UB 10.0

From the **Heart** 

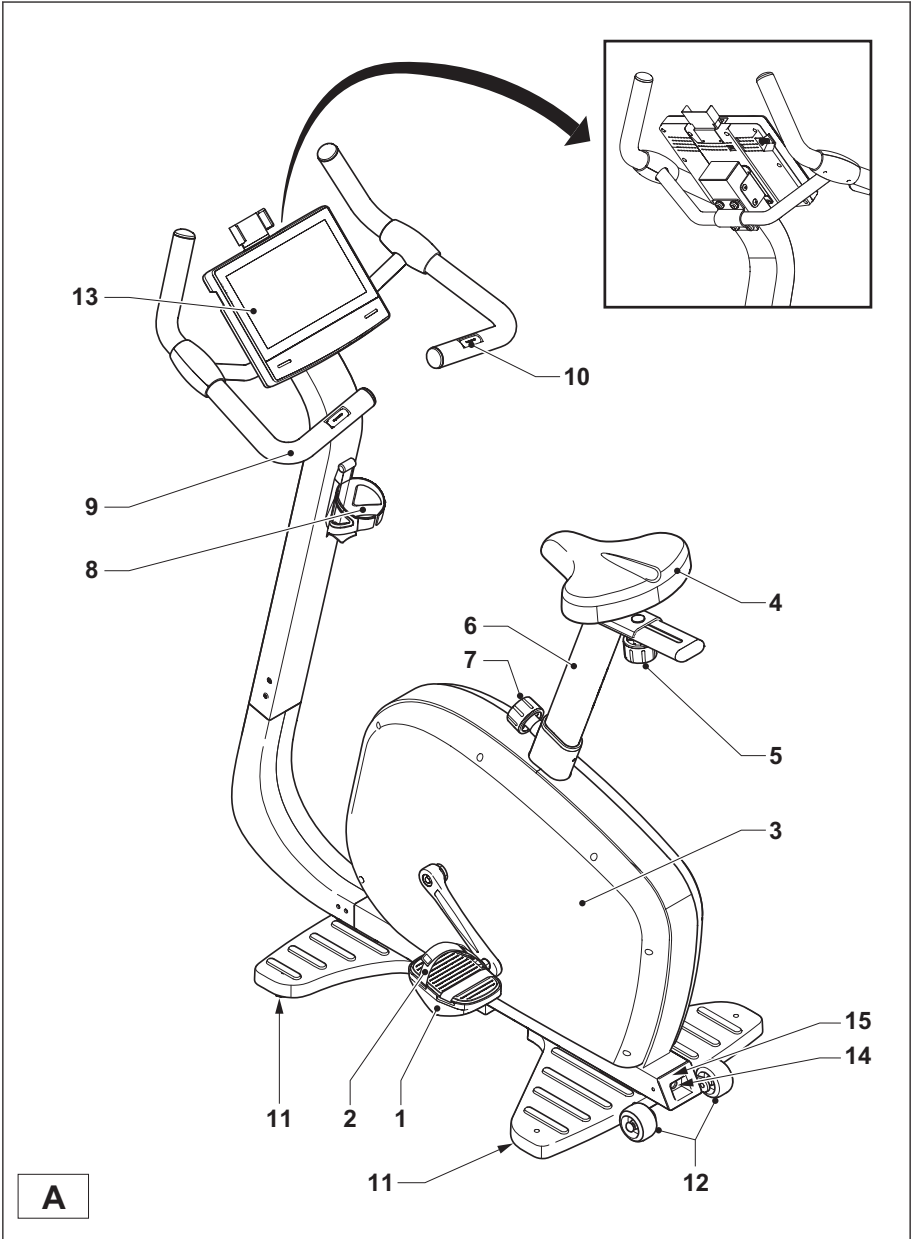

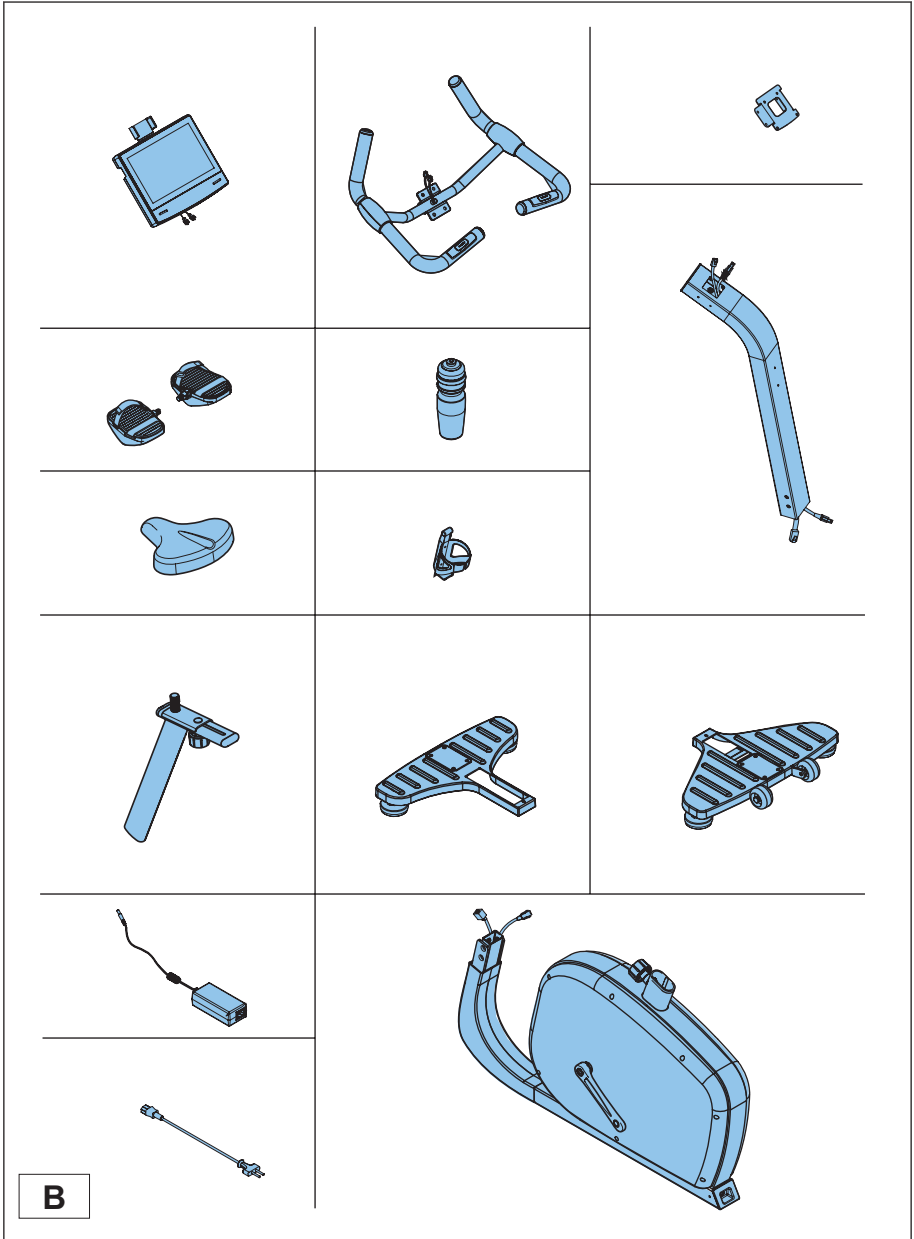

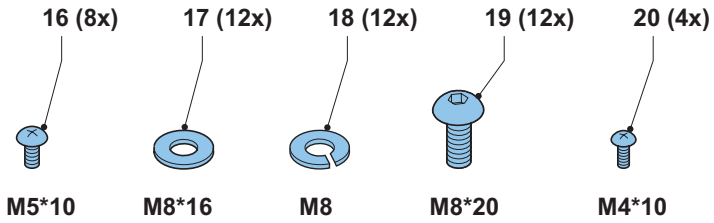

C

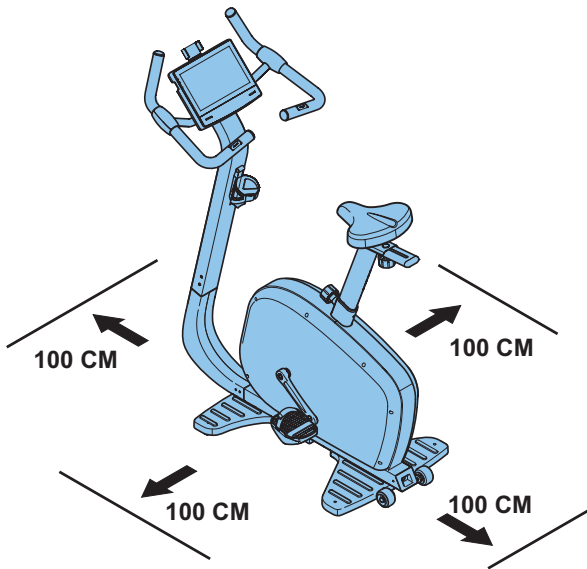

D0

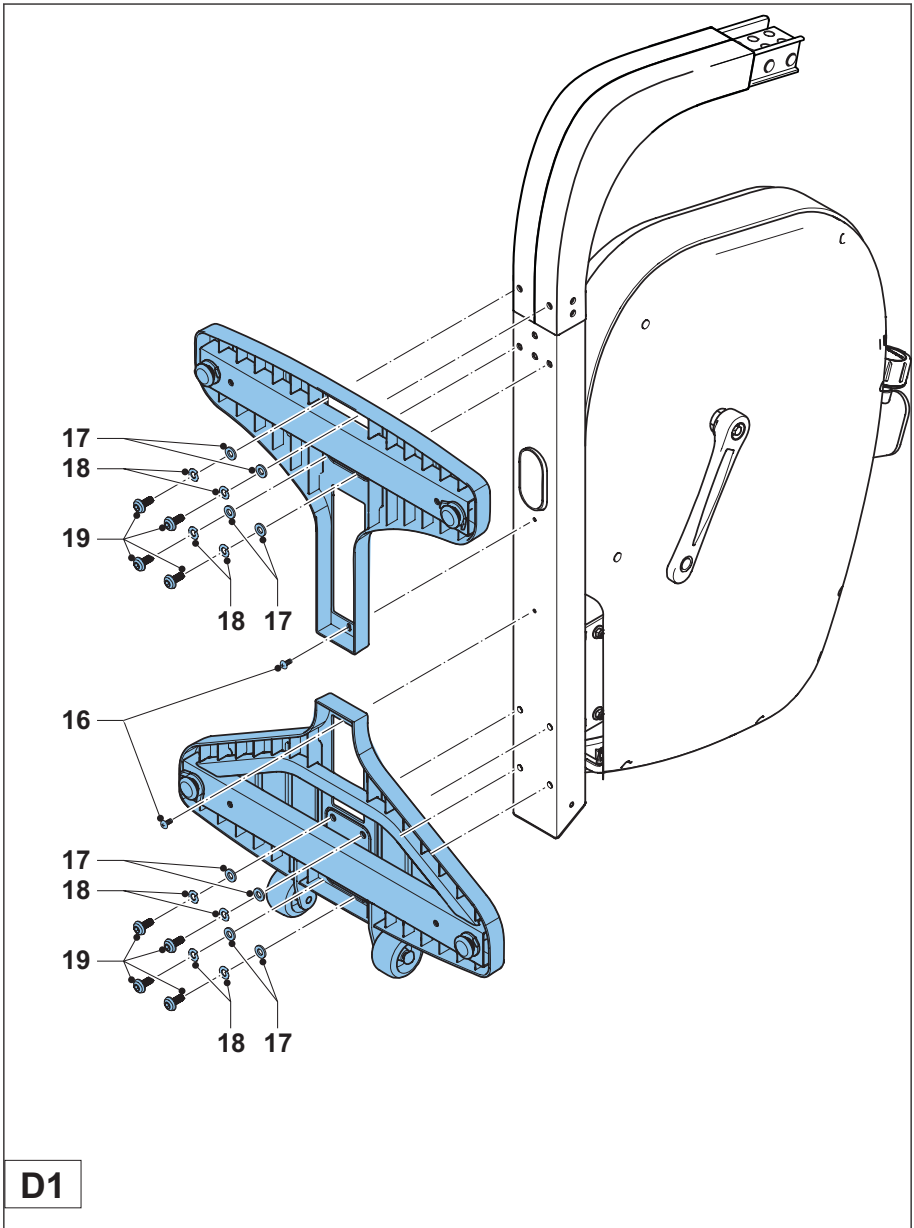

D1

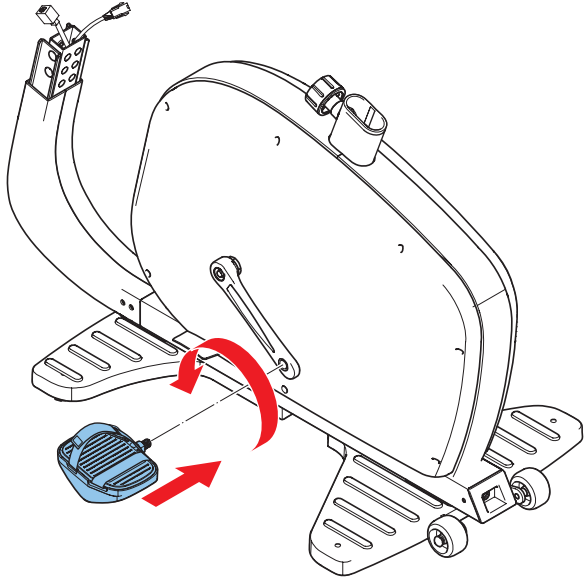
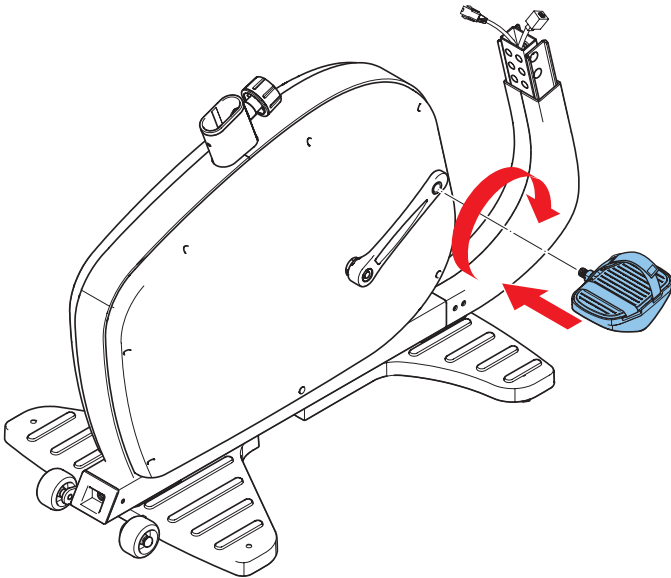
**D2****D3**

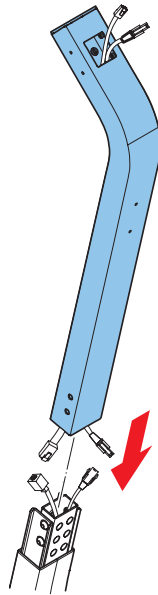
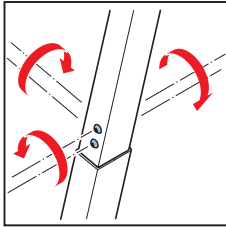
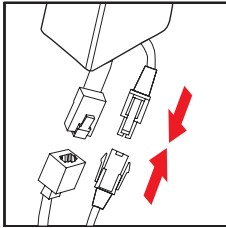

D4

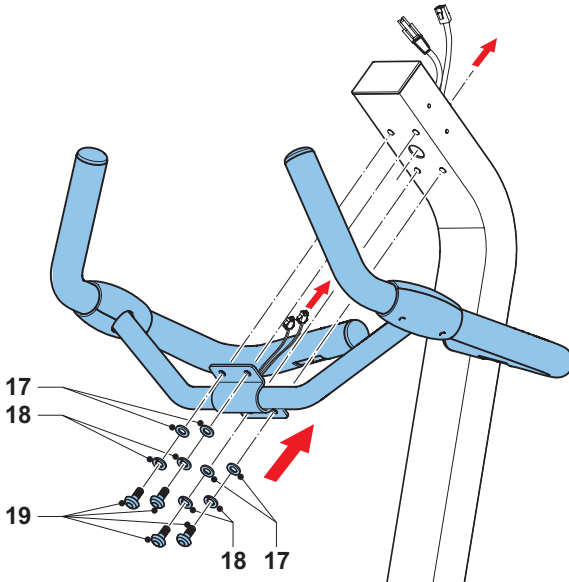

D5

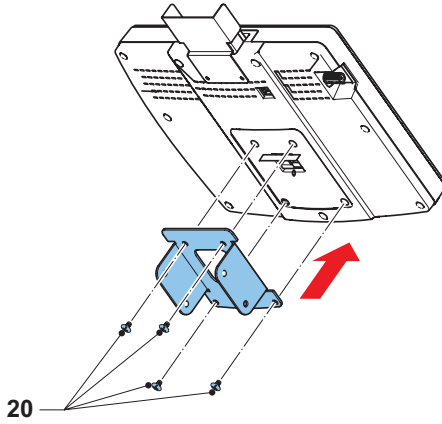

D6

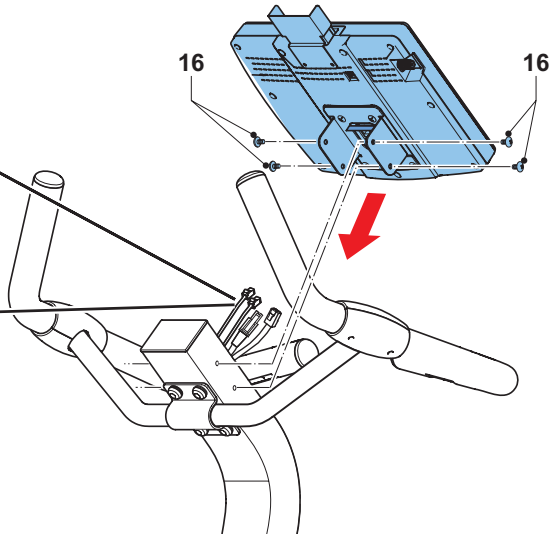
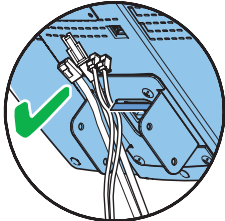
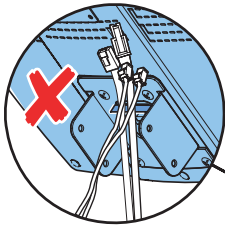

D7

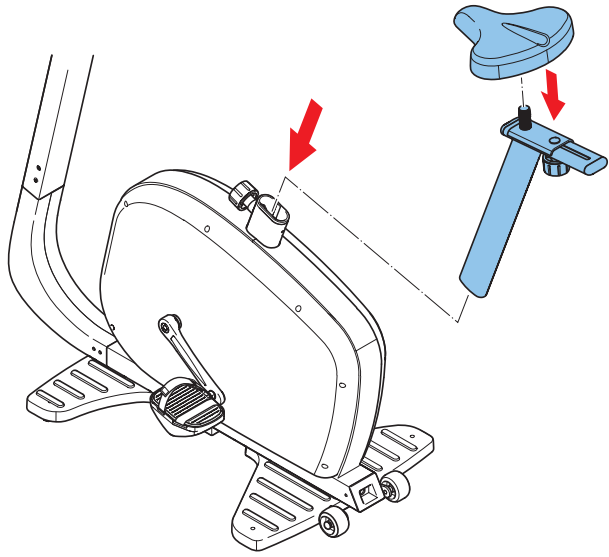
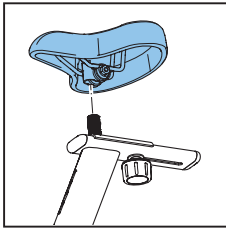

D8

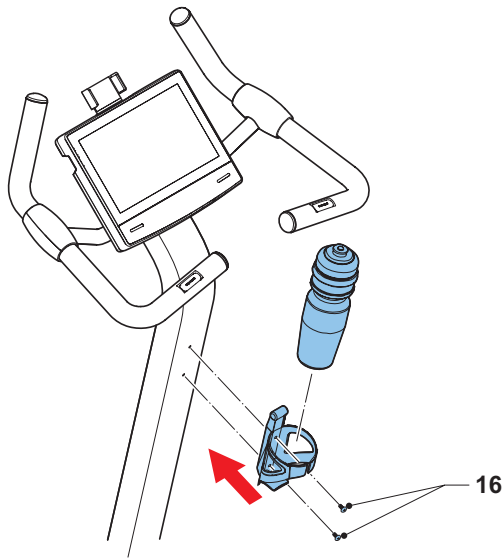

D9

UPRIGHT BIKE

Welcome to the world of Tunturi Fitness!

Thank you for purchasing this piece of Tunturi equipment. Tunturi offers a wide range of professional fitness equipment, including crosstrainers, treadmills, exercise bikes, rowers and vibration plates. The Tunturi equipment is suitable for the entire family, no matter what fitness level. For more information, please visit our website www.tunturi.com

Safety warnings



WARNING

- Read the safety warnings and the instructions. Failure to follow the safety warnings and the instructions can cause personal injury or damage to the equipment. Keep the safety warnings and the instructions for future reference.



WARNING

- Heart rate monitoring systems may be inaccurate. Over exercise may result in serious injury or death. If you feel faint stop exercising immediately.

- The equipment is suitable for domestic and professional use only (e.g. hospitals, fire stations, hotels, schools etc.). Max. usage is limited to 6 hrs a day. The equipment is not suitable for full commercial use (e.g. large gyms).
- The use of this equipment by children or persons with a physical, sensory, mental or motorial disability, or lack of experience and knowledge can give cause to hazards. Persons responsible for their safety must give explicit instructions or supervise the use of the equipment.
- Before starting your workout, consult a physician to check your health.
- If you experience nausea, dizziness or other abnormal symptoms, immediately stop your workout and consult a physician.
- To avoid muscular pain and strain, start each workout by warming up and finish each workout by cooling down. Remember to stretch at the end of the workout.
- The equipment is suitable for indoor use only. The equipment is not suitable for outdoor use.

- Only use the equipment in environments with adequate ventilation. Do not use the equipment in draughty environments in order not to catch a cold.
- Only use the equipment in environments with ambient temperatures between 10 °C and 35 °C. Only store the equipment in environments with ambient temperatures between 5 °C and 45 °C.
- Do not use or store the equipment in humid surroundings. The air humidity must never be more than 80%.
- Only use the equipment for its intended purpose. Do not use the equipment for other purposes than described in the manual.
- Do not use the equipment if any part is damaged or defective. If a part is damaged or defective, contact your dealer.
- Keep your hands, feet and other body parts away from the moving parts.
- Keep your hair away from the moving parts.
- Wear appropriate clothing and shoes.
- Keep clothing, jewelry and other objects away from the moving parts.
- Make sure that only one person uses the equipment at a time. The equipment must not be used by persons weighing more than 150 kg (330 lbs).
- Do not open equipment without consulting your dealer.

Electrical safety (only for equipment with electric power)

- Before use, always check that the mains voltage is the same as the voltage on the rating plate of the equipment.
- Do not use an extension cable.
- Keep the mains cable away from heat, oil and sharp edges.
- Do not alter or modify the mains cable or the mains plug.
- Do not use the equipment if the mains cable or the mains plug is damaged or defective. If the mains cable or the mains plug is damaged or defective, contact your dealer.
- Always fully unwind the mains cable.
- Do not run the mains cable underneath the equipment. Do not run the mains cable underneath a carpet. Do not place any objects on the mains cable.
- Make sure that the mains cable does not hang over the edge of a table. Make sure that the mains cable cannot be caught accidentally or tripped over.
- Do not leave the equipment unattended when the mains plug is inserted into the wall socket.
- Do not pull the mains cable to remove the mains plug from the wall socket.

- Remove the mains plug from the wall socket when the equipment is not in use, before assembly or disassembly and before cleaning and maintenance.

Package contents (fig. B & C)

- The package contains the parts as shown in fig. B.
- The package contains the fasteners as shown in fig. C. Refer to the section "Description".



NOTE

- If a part is missing, contact your dealer.

Description (fig. A)

Your upright bike is a piece of stationary fitness equipment used to simulate cycling without causing excessive pressure to the joints.

1	Pedal	8	Bottle holder
2	Pedal strap	9	Handlebar
3	Main housing	10	Hand pulse sensor
4	Seat	11	Support foot
5	Seat adjustment knob	12	Transport wheel
6	Seat tube	13	Console
7	Seat tube adjustment knob	14	Transformer socket
		15	Serialnumber label

Fasteners (fig. C)

16	Screw (M5*10)	18	Ring (M8)
17	Ring (M8)	19	Screw (M8*20)
		20	Screw (M4*10)

Assembly (fig. D)



WARNING

- Assemble the equipment in the given order.
- Carry and move the equipment with at least two persons.



CAUTION

- Place the equipment on a firm, level surface.
- Place the equipment on a protective base to prevent damage to the floor surface.
- Allow at least 100 cm of clearance around the equipment.

- Refer to the illustrations for the correct assembly of the equipment.

Workouts

The workout must be suitably light, but of long duration. Aerobic exercise is based on improving the body's maximum oxygen uptake, which in turn improves endurance and fitness. You should perspire, but you should not get out of breath during the workout.

To reach and maintain a basic fitness level, exercise at least three times a week, 30 minutes at a time. Increase the number of exercise sessions to improve your fitness level. It is worthwhile to combine regular exercise with a healthy diet. A person committed to dieting should exercise daily, at first 30 minutes or less at a time, gradually increasing the daily workout time to one hour. Start your workout at low speed and low resistance to prevent the cardiovascular system from being subjected to excessive strain. As the fitness level improves, speed and resistance can be increased gradually. The efficiency of your exercise can be measured by monitoring your heart rate and your pulse rate.

Pulse rate measurement (hand pulse sensors)

The pulse rate is measured by sensors in the handlebars when the user is touching both sensors at the same time.

**WARNING**

- Heart rate monitoring systems may be inaccurate. Over exercise may result in serious injury or death. If you feel faint stop exercising immediately.

Most accurate pulse measurement is achieved when the skin is slightly moist and constantly touching the hand pulse sensors. If the skin is too dry or too moist, the pulse rate measurement might become less accurate.

**NOTE**

- Do not use the hand pulse sensors in combination with a heart rate chest belt.
- If you set a heart rate limit for your workout, an alarm will sound when it is exceeded.

Heart rate measurement (heart rate chest belt)

The most accurate heart rate measurement is achieved with a heart rate chest belt. The heart rate is measured by a heart rate receiver in combination with a heart rate transmitter belt. Accurate heart measurement requires that the electrodes on the transmitter belt are slight moist and constantly touching the skin. If the electrodes are too dry or too moist, the heart rate measurement might become less accurate.

WARNING

- If you have a pacemaker, consult a physician before using a heart rate chest belt.

CAUTION

- If there are several heart rate measurement devices next to each other, make sure that the distance between them is at least 2 meter.
- If there is only one heart rate receiver and several heart rate transmitters, make sure that only one person with a transmitter is within transmission range.

**NOTE**

- Do not use a heart rate chest belt in combination with the hand pulse sensors.
- Always wear the heart rate chest belt under your clothes directly in contact with your skin. Do not wear the heart rate chest belt above your clothes. If you wear the heart rate chest belt above your clothes, there will be no signal.
- If you set a heart rate limit for your workout, an alarm will sound when it is exceeded.
- The transmitter transmits the heart rate to the console up to a distance of 1,5 meter. If the electrodes are not moist, the heart rate will not appear on the display.
- Some fibers in clothes (e.g. polyester, polyamide) create static electricity which can prevent accurate heart rate measurement.
- Mobile phones, televisions and other electrical appliances create an electromagnetic field which can prevent accurate heart rate measurement.

Maximum heart rate (during training)

The maximum heart rate is the highest heart rate a person can safely achieve through exercise stress. The following formula is used to calculate the average maximum heart rate: $220 - AGE$. The maximum heart rate varies from person to person.

**WARNING**

- Make sure that you do not exceed your maximum heart rate during your workout. If you belong to a risk group, consult a physician.

Category	Heart rate zone	Explanation
Beginner	50-60% of maximum heart rate	Suitable for beginners, weight-watchers, convalescents and persons who have not exercised for a long time. Exercise at least three times a week, 30 minutes at a time.
Advanced	60-70% of maximum heart rate	Suitable for persons who want to improve and maintain fitness. Exercise at least three times a week, 30 minutes at a time.
Expert	70-80% of maximum heart rate	Suitable for the fittest of persons who are used to long-endurance workouts.

Use

Adjusting the support feet

The equipment is equipped with 4 support feet. If the equipment is not stable, the support feet can be adjusted.

1. Turn the support feet as required to put the equipment in a stable position.
2. Tighten the locknuts to lock the support feet.



NOTE

The machine is the most stable when all support feet are turned fully in. Therefore start to level the machine by turning all support feet fully in, before turning out the required support feet to stable the machine.

Adjusting the horizontal seat position

The horizontal seat position can be adjusted by setting the seat to the required position.

1. Loosen the seat adjustment knob.
2. Move the seat to the required position.
3. Tighten the seat adjustment knob.

Adjusting the vertical seat position

The vertical seat position can be adjusted by setting the seat tube to the required position. With the leg almost straight, the arch of the foot must touch the pedal at its lowermost point.

1. Loosen the seat tube adjustment knob.
2. Move the seat tube to the required position.
3. Tighten the seat tube adjustment knob.

Console (fig. E)

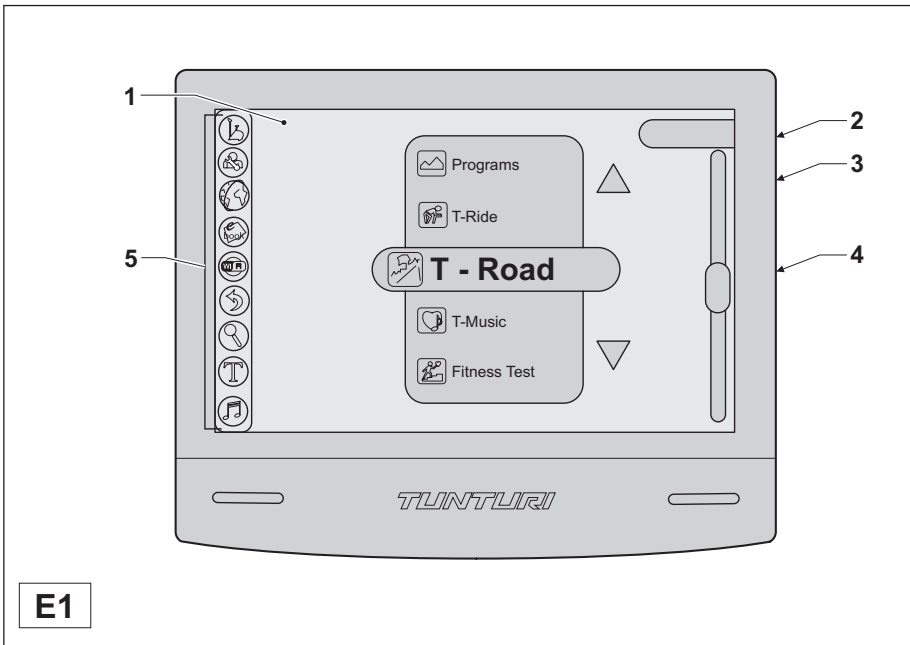
**E1**

- | | | | |
|---|-------------------|---|-----------------------|
| 1 | Display | 4 | BRIGHTNESS +/- button |
| 2 | ON/OFF button | 5 | On-screen buttons |
| 3 | VOLUME +/- button | | |

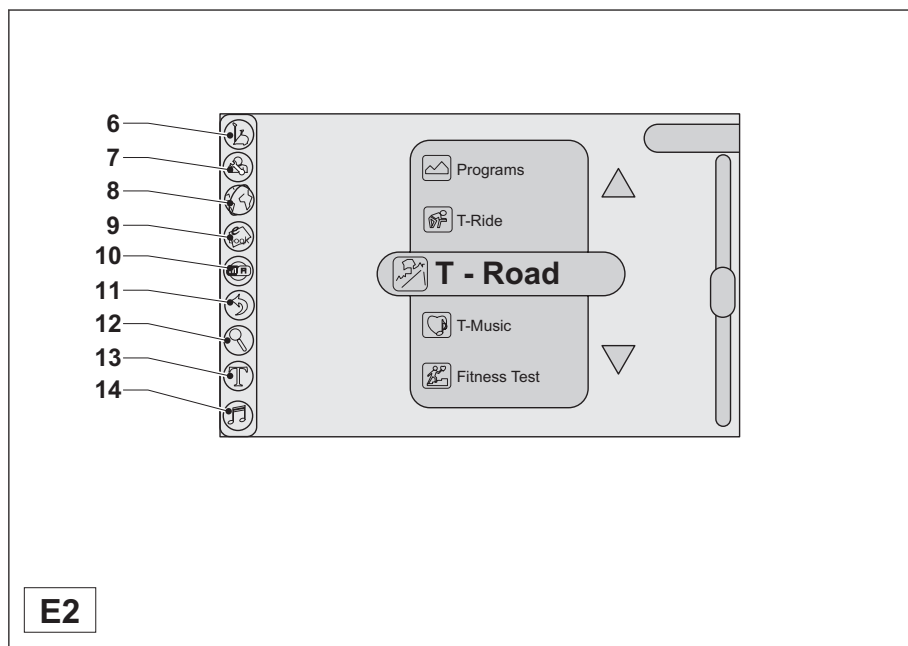

- | | | | |
|----|----------------------|----|------------------|
| 6 | TRAINING button | 11 | BACK/STOP button |
| 7 | USER button | 12 | ZOOM button |
| 8 | INTERNET button | 13 | KEYBOARD button |
| 9 | E-BOOK READER button | 14 | MEDIA button |
| 10 | WIFI button | | |



CAUTION

- Keep the console away from direct sunlight.
- Dry the surface of the console when it is covered with drops of sweat.
- Do not lean on the console.
- Only touch the display with the tip of your finger. Make sure that your nails or sharp objects do not touch the display.



NOTE

- The console switches to standby mode when the equipment is not used for 5 minutes.

Explanation of buttons

Button	Explanation
ON/OFF	Press the button to switch on the console. Press the button again to switch off the console.
VOLUME +/-	Press the left-arrow button to decrease the volume. Press the right-arrow button to increase the volume.
BRIGHTNESS +/-	Press the left-arrow button to decrease the brightness. Press the right-arrow button to increase the brightness.
TRAINING	Touch the button to go to the training menu. Menu items: QUICK START / MANUAL / TARGET HR / WATT CONTROL / PROGRAMS / T-RIDE / T-ROAD / T-MUSIC / OWN TRAINING / FITNESS TEST.
USER	Touch the button to go to the user menu. Menu items: CREATE USER / CHANGE USER / SETTINGS / EDIT USER / DELETE USER / USER LOG.
INTERNET	Touch the button to browse the internet (WiFi only, no flashplayer available).
E-BOOK READER	Touch the button to open the E-Book reader. The console recognises E-Books which are stored on your USB stick. Supported formats: ePub, FictionBook (fb2), Plucker, Open E-Book, Open Reader, PalmDOC, Psion Text, Mobipocket, TXT (plain text). No PDF available.
WIFI	Touch the button to set up your network connection.
BACK/STOP	Before use: Touch the button to return to the main menu.

Button	Explanation
	During use: Touch the button again to pause the training (max. 4 minutes). Touch the button again to continue the training. Touch and hold the button to stop the training.
ZOOM	Touch the button to increase or decrease the size of the displayed profile image. Zoom options: 1x / 2x / 4x / 8x / 16x.
KEYBOARD	Press the button to show or hide the keyboard.
MEDIA	Touch the button to open the media player. The console recognises music and movies which are stored on your USB stick. Supported formats: MP3, WAV, WMP (music); MPEG-1, MPEG-4, AVI, DivX (movies).

Explanation of menu items

Refer to the section "Training menu".

User menu

The console can store a maximum of 20 users.

Creating a user

1. Touch the USER button to go to the user menu.
2. Scroll the list to select CREATE USER. Touch the menu item to confirm.
3. Scroll the list to select the language. Touch the menu item to confirm.
4. Enter your name. Touch ENTER to confirm.
5. Scroll the list to set the metric system or the imperial system as the default system of measurement. Touch the menu item to confirm.
6. Scroll the list to set whether the display must count up or count down during workouts. Touch the menu item to confirm.
7. Scroll the list to set your sex. Touch the menu item to confirm.
8. Move the slider to set your age. Touch the menu item to confirm.
9. Move the slider to set your height. Touch SELECT to confirm.
10. Move the slider to set your weight. Touch SELECT to confirm.
11. Move the slider to set the heart rate limit. Touch SELECT to confirm.

12. Move the slider to set the anaerobic heart rate. Touch SELECT to confirm.
13. Move the slider to set the aerobic heart rate. Touch SELECT to confirm.

Selecting a user

1. Touch the USER button to go to the user menu.
2. Scroll the list to select CHANGE USER. Touch the menu item to confirm.
3. Scroll the list to select the user. Touch the menu item to confirm.

Editing a user

1. Touch the USER button to go to the user menu.
2. Select the user. Refer to the section "Selecting a user".
3. Scroll the list to select EDIT USER. Touch the menu item to confirm.
4. Scroll the list to edit user data. Touch the menu item to confirm.

Deleting a user

1. Touch the USER button to go to the user menu.
2. Select the user. Refer to the section "Selecting a user".
3. Scroll the list to select DELETE USER. Touch the menu item to confirm.
4. Scroll the list to delete the current user. Touch YES to confirm.

User log

1. Touch the USER button to go to the user menu.
2. Select the user. Refer to the section "Selecting a user".
3. Scroll the list to select USER LOG. Touch the menu item to confirm. The display shows the data of the last training session of the current user. The display shows the data of all training sessions of all users.
4. Touch the BACK/STOP button to return to the user menu.

Settings

Training menu

The training menu contains 10 training options.

QUICK START

1. Touch the TRAINING button to go to the training menu.
2. Scroll the list to select QUICK START. Touch the menu item to confirm.
3. Set the equipment in motion to start the workout.
4. Manually change the resistance during the workout: Move the slider to set the resistance (1-58 Nm).

5. Touch the BACK/STOP button to stop the workout.
6. Touch EXIT to stop the workout. Touch SAVE AND EXIT to save and stop the workout.

MANUAL

1. Touch the TRAINING button to go to the training menu.
2. Scroll the list to select MANUAL. Touch the menu item to confirm.
3. Touch the corresponding menu item to set the time, the distance or the energy consumption.
4. Move the slider to change the value for the selected menu item. Touch SELECT to confirm.
5. Set the equipment in motion to start the workout. If you have set target values, the values start to count up or count down.
6. Manually change the resistance during the workout: Move the slider to set the resistance.
7. When you have reached the target values, an alarm will sound. You can continue with your workout.
8. Touch the BACK/STOP button to stop the workout.
9. Touch EXIT to stop the workout. Touch to SAVE AND EXIT to save and stop the workout.

TARGET HR

The program requires heart rate measurement.

1. Touch the TRAINING button to go to the training menu.
2. Scroll the list to select TARGET HR. Touch the menu item to confirm.
3. Move the slider to set the target heart rate. Touch SELECT to confirm.
4. Touch the corresponding menu item to set the time, the distance or the energy consumption.
5. Move the slider to change the value for the selected menu item. Touch SELECT to confirm.
6. Set the equipment in motion to start the workout. If you have set target values, the values start to count up or count down.
7. Manually change the target heart rate during the workout: Move the slider to set the target heart rate.
8. When you have reached the target values, an alarm will sound. You can continue with your workout.
9. Touch the BACK/STOP button to stop the workout.

10. Touch EXIT to stop the workout. Touch to SAVE AND EXIT to save and stop the workout.

WATT CONTROL

1. Touch the TRAINING button to go to the training menu.
2. Scroll the list to select WATT CONTROL. Touch the menu item to confirm.
3. Move the slider to set the resistance. Touch SELECT to confirm.
4. Touch the corresponding menu item to set the time, the distance or the energy consumption.
5. Move the slider to change the value for the selected menu item. Touch SELECT to confirm.
6. Set the equipment in motion to start the workout. If you have set target values, the values start to count up or count down.
7. Manually change the resistance during the workout: Move the slider to set the resistance.
8. When you have reached the target values, an alarm will sound. You can continue with your workout.
9. Touch the BACK/STOP button to stop the workout.
10. Touch EXIT to stop the workout. Touch to SAVE AND EXIT to save and stop the workout.

PROGRAMS

The program contains 10 preset training profiles. Profiles P1-P5 are watt control programs. Profiles P6-P10 are heart rate control programmes requiring heart rate measurement.

The training profiles are adjusted to the fitness level of the user:

	P1	P2	P3	P4	P5	P6	P7	P8	P9	P10
Beginner	x	x				x	x			
All			x		x			x		
Fit				x					x	x

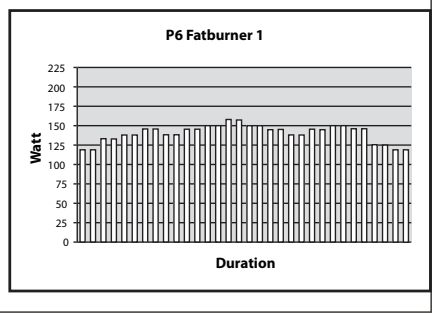
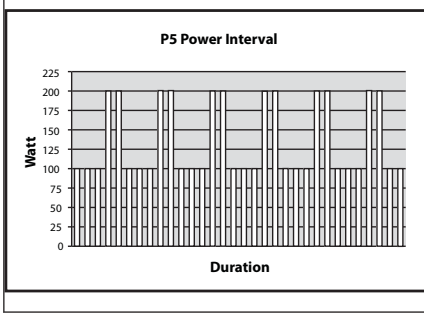
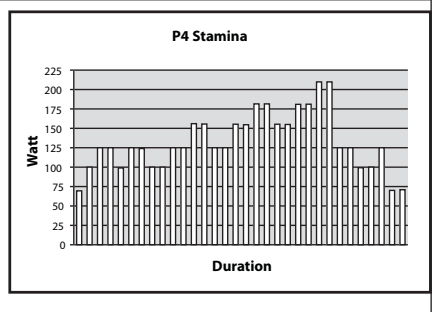
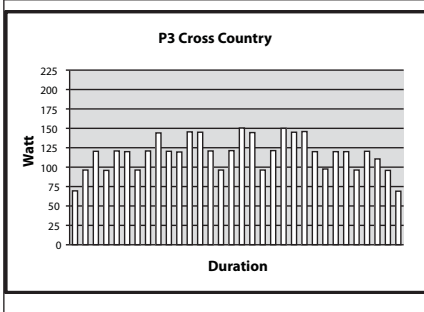
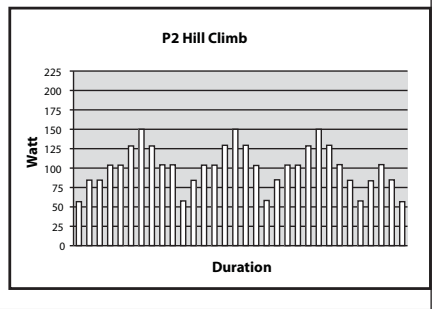
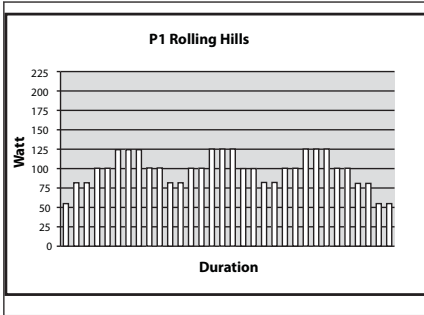

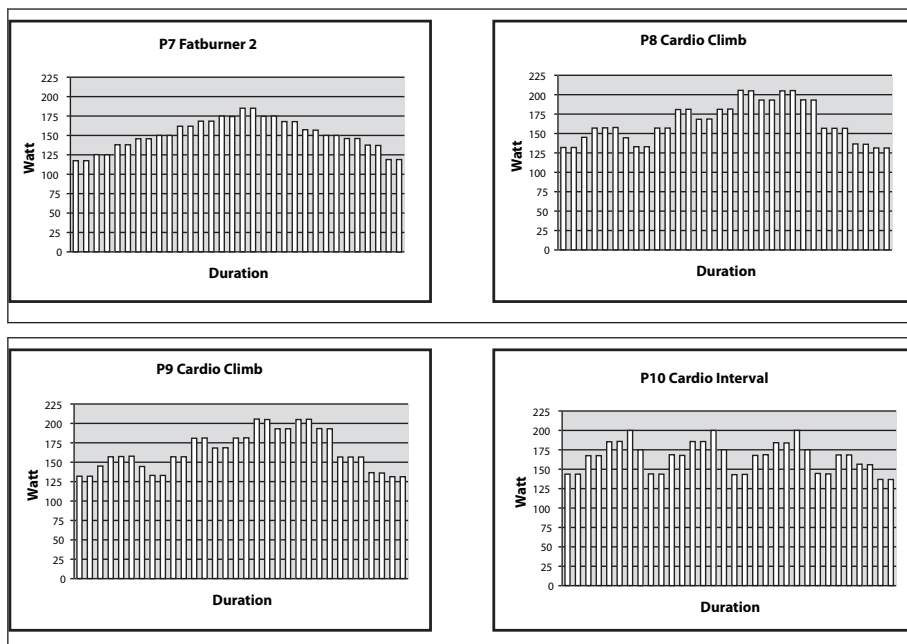

1. Touch the TRAINING button to go to the training menu.
2. Scroll the list to select PRESET PROGRAMS. Touch the menu item to confirm.
3. Scroll the list to select a training profile. Touch the menu item to confirm.
4. Touch the corresponding menu item to set the time or the distance.
5. Move the slider to change the value for the selected menu item. Touch SELECT to confirm.
6. Set the equipment in motion to start the workout. If you have set target values, the values start to count up or count down.
7. Manually change the resistance during the workout: Move the slider to set the resistance.
8. When you have reached the target values, an alarm will sound. You can continue with your workout.
9. Touch the BACK/STOP button to stop the workout.
10. Touch EXIT to stop the workout. Touch to SAVE AND EXIT to save and stop the workout.

T-RIDE

1. Touch the TRAINING button to go to the training menu.
2. Scroll the list to select T-RIDE. Touch the menu item to confirm.
3. Scroll the list to select the terrain. Touch the menu item to confirm.
4. Move the red bar on the left side to the required position to set the starting point for your workout. Touch SET START to confirm.
5. Move the red bar on the right side to the required position to set the ending point for your workout. Touch SET END to confirm.
6. Set the equipment in motion to start the workout.
7. Manually change the gear during the workout: Move the slider to set the gear.
8. When you have reached the ending point, an alarm will sound.
9. Touch the BACK/STOP button to stop the workout.
10. Touch EXIT to stop the workout. Touch to SAVE AND EXIT to save and stop the workout.

T-ROAD

IMPORTANT:

You can only carry out a T-ROAD training session when the memory stick is inserted in the meter. T-ROAD is similar to T-RIDE, but during a T-ROAD training session, you can also see your progress on a video. During training, you can display the altitude profile or video using the selection dial.

T-MUSIC

IMPORTANT:

You can only carry out a T-MUSIC training session when the memory stick is inserted in the meter. T-MUSIC programs are controlled by heart rate. During training, the music tempo changes according to the effort level of the training session. The duration of the T-MUSIC program is 40 minutes. You cannot change the selected heart rate level during training. The program requires measurement of heart rate.

1. Select T-MUSIC.
2. Select a program (1–3) by scrolling the list. Confirm your selection by pressing the selection bar.
3. Start the program by pedaling. During training, you can display effort or heart rate using the button at the bottom of the screen.
4. After 40 minutes, the meter beeps and the training session ends.

5. To stop the training session, press the BACK/STOP button. You can then stop the session by selecting EXIT, save the session to the memory by selecting SAVE AND EXIT or continue your training session by selecting CONTINUE.

OWN TRAINING

The console can store a maximum of 100 workouts longer than 10 minutes. You can only save workouts after selecting a user.

You can repeat a previously saved workout (REPLAY), edit the duration of a previously saved workout (EDIT) or compete against a previously saved workout (RACE). You can also delete a previously saved workout (DELETE).

1. Touch the BACK/STOP button to stop the workout.
2. Touch SAVE AND EXIT to save and stop the workout.
3. Enter the name for the training program. Touch ENTER to confirm.
4. Touch the TRAINING button to go to the training menu.
5. Scroll the list to select OWN TRAINING. Touch the menu item to confirm.
6. Scroll the list to select the training program. Touch the menu item to confirm.
7. Touch the corresponding menu item to select REPLAY, EDIT or RACE. Touch SELECT to confirm.
8. If you select EDIT, move the slider to set the time. Touch SELECT to confirm.
9. If you select RACE, scroll the list to select to select the race mode: TIME (distance you can travel in a given time) or DISTANCE (time in which you can travel a given distance). Touch SELECT to confirm. The display shows a previously saved workout. The dashed line shows whether you are ahead or behind the benchmark workout (most recently saved workout using this training program). The blue vertical dash line shows the previously saved workout. The black vertical dash line shows your race effort.
10. Set the equipment in motion to start the workout.
11. Manually change the resistance during the workout: Move the slider to set the resistance.
12. Touch the BACK/STOP button to stop the workout.
13. Touch EXIT to stop the workout. Touch to SAVE AND EXIT to save and stop the workout.

FITNESS TEST

The program concerns a multi-step fitness test, starting at a low level of effort and gradually increasing speed and resistance in accordance with the selected test type. The multi-step test is a safe and reliable means of measuring a person's physical

fitness level. The test continues until the test subject has achieved the individual target heart rate (85% of maximum heart rate). The test requires a heart rate chest belt.

The console shows three fitness categories:

- ATHLETIC = active training, good or excellent physical condition;
- ACTIVE = regular exercise, average or good physical condition;
- INACTIVE = no regular exercise, poor physical condition.

For each fitness category, the display shows the appropriate test type: STEP TIME = duration of different effort levels; FIRST STEP = initial effort level; STEP POWER = effort level of each step.

1. Touch the TRAINING button to go to the training menu.
2. Scroll the list to select FITNESS TEST. Touch the menu item to confirm.
3. Scroll the list to set the fitness category. Touch the menu item to confirm.
4. Move the slider to set the target heart rate. Touch SELECT to confirm.
5. Set the equipment in motion to start the workout.
6. Manually change the target heart rate during the workout: Move the slider to set the resistance.
7. When you have reached the target heart rate, an alarm will sound. It is recommended to stop your workout.
8. Touch the BACK/STOP button to stop the workout. The display shows the test results.

PREPARING FOR THE TEST

1. Make sure that the data associated with your username is updated – the meter uses the user data as a basis for the fitness test.
2. Select FITNESS TEST.
3. Using the selection dial, select the most suitable fitness category for you: a. Inactive = no regular exercise, poor physical condition b. Active = regular exercise, average or good physical condition c. Athletic = active training, good or excellent physical condition
4. The display shows the appropriate test type for each fitness category:
 - Step time = duration of different effort levels in the test
 - First step = initial effort level
 - Step power = effort level of steps (in Watts), the test features several steps
5. Confirm your selection by pressing the selection dial.
6. If necessary, you can adjust your target heart rate value using the selection dial. Confirm your settings using the selection dial.

-
7. The display informs you that you can stop the test once you reach the target heart rate for the test. Start the test by pressing the selection dial.

PERFORMING THE TEST

1. 1. The display shows the selected test step type. Start pedalling to begin the test. A red diagram that updates as you progress in the test represents your heart rate. A discontinuous line in red indicates your target heart rate.
2. 2. Once the target heart rate level has been achieved, the meter gives an audio signal and displays a message. We recommend that you end the test here, unless you are relatively fit. If you have set your target heart rate correctly (that is, if you have calculated your maximum heart rate accurately enough), continuing the test beyond this point will not increase the accuracy of the result. If you overestimate your maximum heart rate, your fitness level will be overestimated. Similarly, if you underestimate your maximum heart rate, your fitness level will be underestimated.
3. 3. To stop the test once you reach the target heart rate level, press the BACK/STOP button or stop pedalling. The meter will now switch to the test result display:
 - A) Aerobic fitness = an estimate of your fitness level in your regular effort zone, which gives the best indication of the state of your health related fitness.
 - B) MET value = a reading that shows the multiple of your maximum oxygen uptake at complete rest.
 - C) ml/kg/min = a reading that tells how many millilitres of oxygen per kilogram of body weight per minute your body consumes.
 - D) l/min = a reading that tells your oxygen uptake in litres per minute. Unlike the above values, l/min does not take account of the user's body weight.
 - E) W_{max} = an estimate of your maximal exercise power, measured in Watts.
 - F) Watt/kg = the ratio of your maximal exercise power to your weight.

MEN / MAXIMAL OXYGEN UPTAKE (VO2MAX) 1 = VERY POOR - 7 = EXCELLENT							
AGE	1	2	3	4	5	6	7
18-19	<33	33-38	39-44	45-51	52-57	58-63	> 63
20-24	<32	32-37	38-43	44-50	51-56	57-62	> 62
25-29	<31	31-35	36-42	43-48	49-53	54-59	>59
30-34	<29	29-34	35-40	41-45	46-51	52-56	> 56
35-39	<28	28-32	33-38	39-43	44-48	49-54	> 54
40-44	<26	26-31	32-35	36-41	42-46	47-51	> 51
45-49	<25	25-29	30-34	35-39	40-43	44-48	>48
50-54	<24	24-27	28-32	33-36	37-41	42-46	>46
55-59	<22	22-26	27-30	31-34	35-39	40-43	> 43
60-65	<21	21-24	25-28	29-32	33-36	37-40	>40

MEDIA

This monitor supports 2 USB ports (FAT/FAT32 format), for playing media files. Supported file types: MP3, AAC (MP4), Ogg Vorbis, WAV, MPEG-1, MPEG-4 AVI, DivX, Ogg Theora, AVI, MKV, Ogg, MOV. Playback of DRM protected files is not supported. Also an IPod/iPhone (30 pin) connector is present, which can connect most Apple products. You can use the Media button to browse and play the music found on your IPod/iPhone. Video cannot be played through this connection. You can access the music files of your IPod/iPhone in the folder user/Apple. Press the + button to add your choice to the playlist and - button to delete.

NOTE

This monitor offers the possibility to connect your IPod/Phone, Tunturi is not liable for any damages done to your IPod/iPhone due to connecting in both hardware and software. ON SCREEN

Cleaning and maintenance

Defects and malfunctions

Despite continuous quality control, defects and malfunctions caused by individual parts can occur in the equipment. In most cases, it will be sufficient to replace the defective part.

1. If the equipment does not function properly, immediately contact the dealer.
2. Provide the model number and the serial number of the equipment to the dealer. State the nature of the problem, conditions of use and purchase date.

Transport and storage



WARNING

- Carry and move the equipment with at least two persons.

1. Remain standing in front of the equipment on each side and take a sturdy grip at the handlebars. Lift the front of the equipment so as to lift the rear of the equipment on the wheels. Move the equipment and carefully put the equipment down. Place the equipment on a protective base to prevent damage to the floor surface.
2. Move the equipment carefully over uneven surfaces. Do not move the equipment upstairs using the wheels, but carry the equipment by the handlebars.
3. Store the equipment in a dry place with as little temperature variation as possible.

Technical data

Parameter	Unit of measurement	Value
Flywheel/Rotating mass		9kg/16kg
Power Output		440W/60RPM
Length	cm inch	106 42
Width	cm inch	56.5 22
Height	cm inch	143 57
Weight	kg lbs	54 119
Max. user weight	kg lbs	150 300
Adapter		26V/3.46A

Warranty

The product has a warranty from the date of delivery (to be documented by invoice or delivery note). Further information on warranty terms can be obtained from your local dealer. The warranty terms may vary from one country to another. Damages caused by normal wear, overloading or improper handling are excluded from the warranty. Damages caused by material or manufacturing faults are covered by the warranty and will be repaired or replaced at no cost.

Declaration of the manufacturer

Tunturi Fitness BV declares that the product is in conformity with the following standards and directives: EN 957 (HA), 89/336/EEC. The product therefore carries the CE label.

10-2012

Tunturi Fitness BV
P.O. Box 60001
1320 AA Almere
The Netherlands

Disclaimer

© 2012 Tunturi Fitness BV
All rights reserved.

The product and the manual are subject to change. Specifications can be changed without further notice.

TUNTURI®

Tunturi Fitness BV
PO Box 60001
1320 AA Almere
The Netherlands
Tel: +31 36 5460050
Fax: + 31 36 5460055

For contact information and manuals in other languages, check our website:

www.tunturi.com