

TUNTURI®

MANUAL

FREE STAND PUNCH BAG

14TUSBO096



FEEL BETTER **EVERY DAY**

More info



PARTS

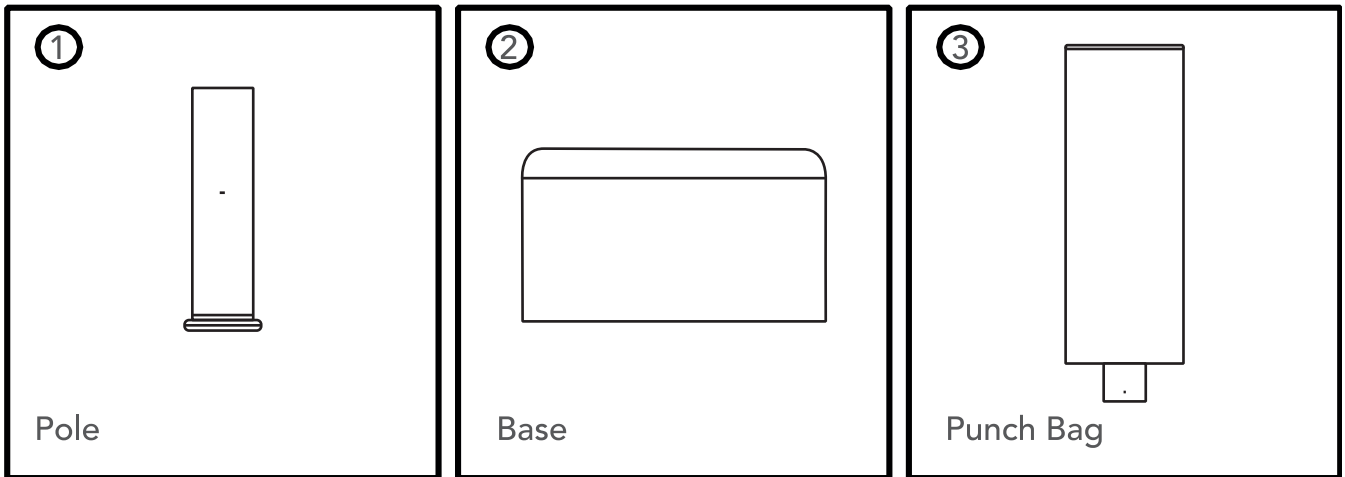

SETUP

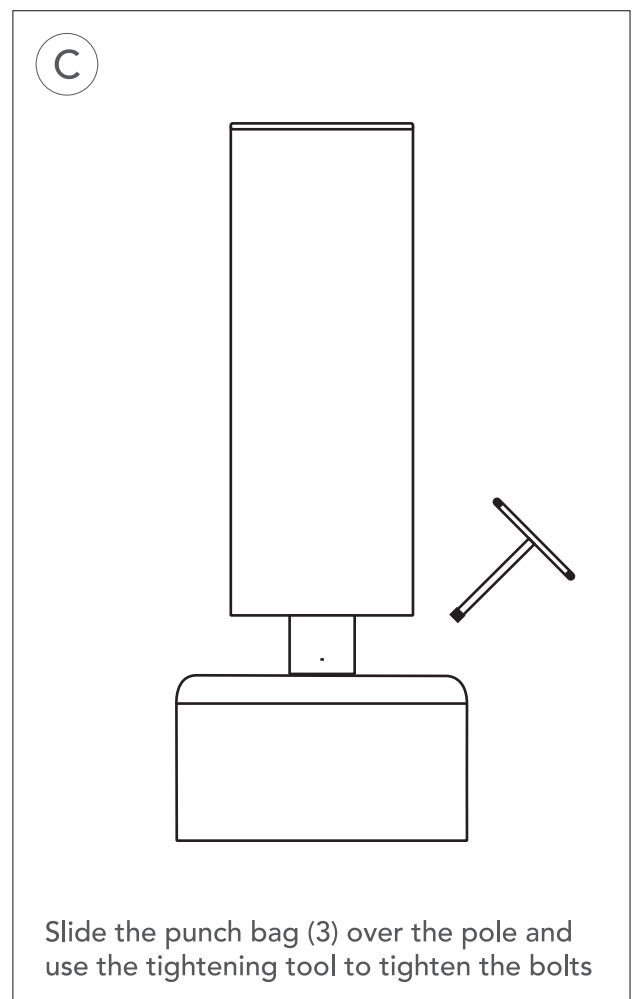
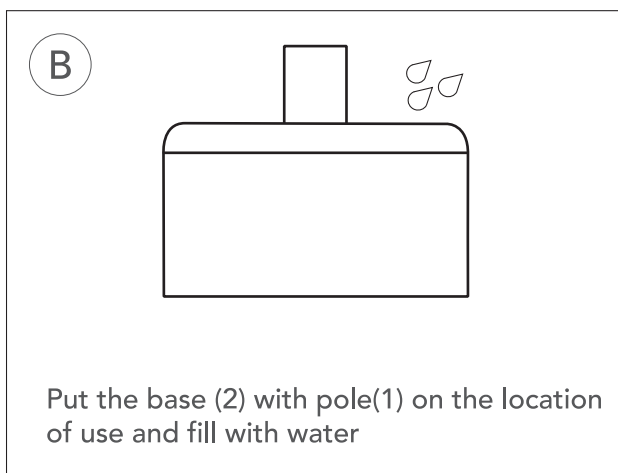
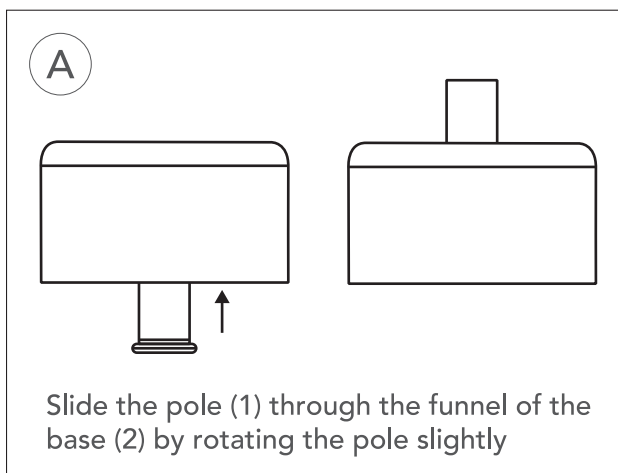

MAINTENANCE AND SAFE USE OF THE PUNCH BAG

- When using the punch bag, you should always wear padded gloves or mitts in order to avoid abrasions or other injuries. Similar protection should be used for feet, arms, and legs if the punch bag is used for kickboxing or other similar sport. However, the punch bag should not be used for such activities without proper instructions.
- The punch bag will move when it is punched. It is therefore important to make sure that the bag is put in such a way that it will not hit walls or other items nearby. This must be done to avoid damage to the bag and to avoid that the bag causes damage to people or animals when it is in use.