

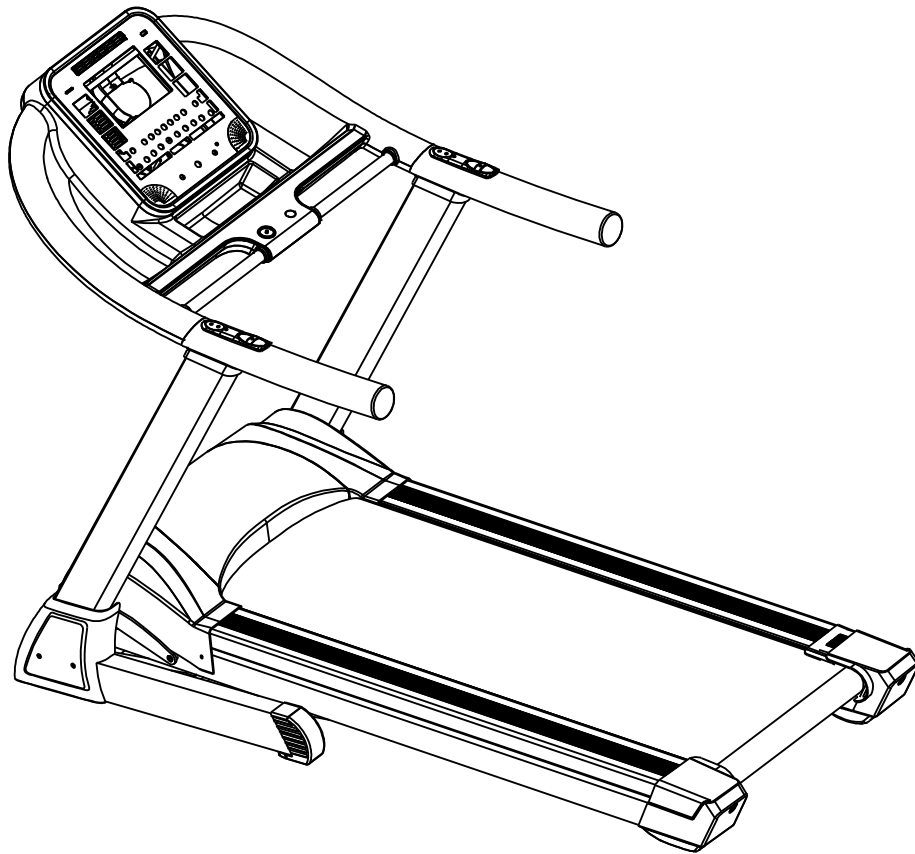

USER MANUAL – EN

IN 6935 Motorized Treadmill inSPORTline Mystral



CONTENTS

- GENERAL SAFETY INSTRUCTIONS 3
- ASSEMBLY 4
- SETTING UP YOUR TREADMILL 9
- SPECIAL SAFETY PRECAUTIONS 10
- GENERAL FUNCTIONALITIES 11
- CONSOLE 12
- ERROR MESSAGE AND SOLUTIONS 18
- TREADMILL MAINTENANCE 19
- EXPLODED DRAWING 22
- PARTS LIST 23
- GENERAL FITNESS TIPS 26
- WARM-UP / STRETCHING EXERCISES 26
- TERMS AND CONDITIONS OF WARRANTY, WARRANTY CLAIMS 28

Thank you

Thanks for purchasing this product. The product will help you exercise your muscles in the correct way and to improve your fitness – and all this in a familiar environment.

GENERAL SAFETY INSTRUCTIONS

A great deal of emphasis was placed on safety in the design and manufacture of this fitness device. Still, it is very important that you strictly adhere to the following safety instructions. We cannot be held liable for accidents that were caused due to disregard.

To ensure your safety and to avoid accidents, please read through the operating instructions thoroughly and attentively before you use the sports device for the first time.



- 1) Consult your GP before starting to exercise on this device. Should you want to exercise regularly and intensively, the approval of your GP would be advisable. This is especially true for users with health problems.
- 2) We recommend that handicapped people should only use the device when a qualified care is present.
- 3) When using the fitness device, wear comfortable clothing and preferably sports or aerobic shoes. Avoid wearing loose clothing which could get caught in the moving parts of the device.
- 4) Stop exercising immediately should you feel unwell or if you feel pain in your joints or muscles. In particular, keep an eye on how your body is responding to the exercise program. Dizziness is a sign that you are exercising too intensively with the device. At the first signs of dizziness, lay down on the ground until you feel better.
- 5) Ensure there are no children nearby when you are exercising on the device. In addition, the device should be stowed in a place that children or house pets cannot reach.
- 6) Ensure that only one person at a time uses the fitness device.
- 7) No adjustable part should protrude to obstruct user's movements.
- 8) After the sports device has been set up according to operating instructions, make sure all screws, bolts and nuts are correctly fitted and tightened. Use only attachments recommended and/or supplied by the importer.
- 9) Do not use a device that is damaged or unserviceable. Regularly check that all bolts and nuts are firmly tightened. Damaged or worn parts must be replaced immediately.
- 10) Always place the device on a smooth, clean and sturdy surface. Never use near water and make sure there are no pointed objects in the direct vicinity of the fitness device. If necessary, place a protective mat (not included in scope of delivery) to protect your floor underneath the device and keep a free space of at least 0.6 m around the device for safety reasons.
- 11) Take care not to put your arms and legs near moving parts. Do not place any material in openings in the device.
- 12) Use the device only for the purposes described in these operating instructions. Use only attachments recommended by the manufacturer
- 13) If the supply cord is damaged, it must be replaced by the manufacturer, its service agent or similarly persons in order to avoid a hazard.
- 14) Category SC (according to EN957) for commercial use.
- 15) Maximum user weight is 150 kg.
- 16) For safety reasons, the equipment should have at least 0.6 meter of free space all around it.
- 17) **WARNING!** The heart rate frequency monitoring may not be completely accurate. Overexertion during training can lead to a serious injury or even death. If you start to feel faint, stop the exercise immediately.

ASSEMBLY

- Before starting with the assembly of this fitness device, carefully read through the set up steps as of page 7 We also recommend that you view the assembly drawing prior to assembly.
- Remove all packaging material and place the individual parts on a free surface. This will provide you with an overview and will simplify assembly.
- Please consider that there is always the risk of injury when using tools and carrying out technical activities. Please proceed with care when assembling the device.
- Make sure you have a hazard-free working environment and do not, for example, leave tools lying around. Deposit the packaging material in such a way that it does not pose a danger. Foil/plastic bags are a potential risk of suffocation for children!
- Take your time when viewing the drawings and then assemble the device according to the series of illustrations.
- The device must be carefully assembled by an adult person. If necessary, request aid from another technically talented person.

UNPACK AND VERIFY THE CONTENTS OF THE BOX:

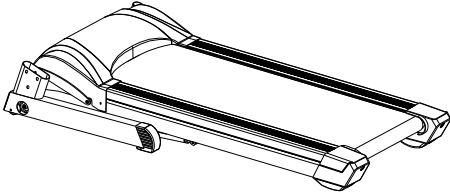
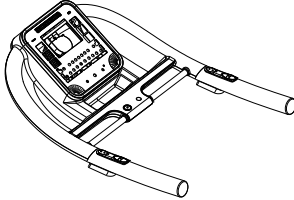
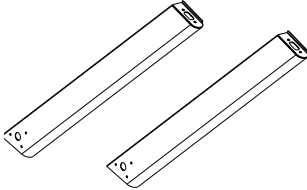
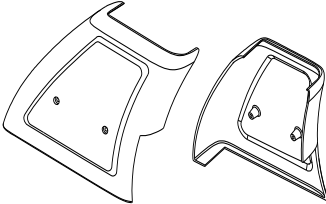
- Lift up and remove the box that surrounds the Treadmill.
- Check the following items are present. If any of the parts are missing, contact with the dealer.

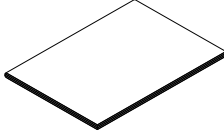
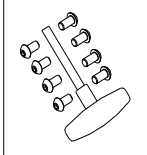
 <p>Main frame and base</p>	 <p>Console</p>
 <p>Stand post</p>	 <p>Base cover</p>
 <p>Silicone oil</p>	 <p>Safety key</p>
 <p>User manual</p>	 <p>Hardware kit</p>

MAIN PARTS OF THE TREADMILL:

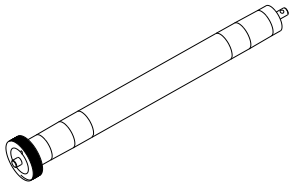
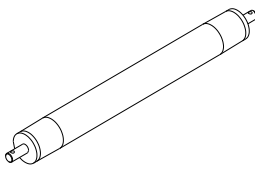
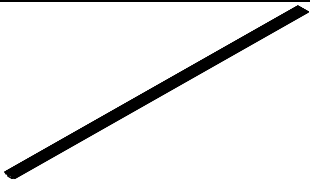
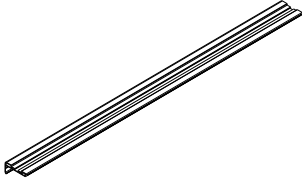
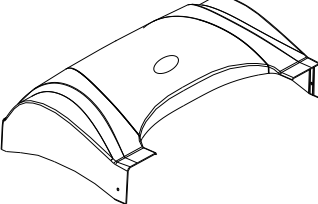
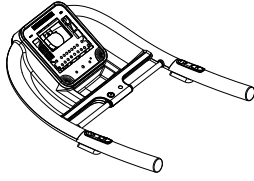
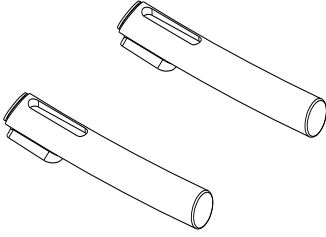
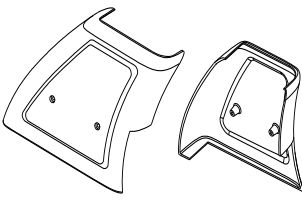
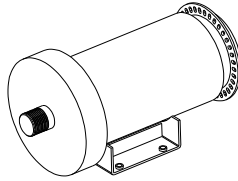
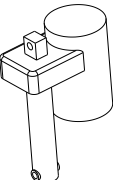
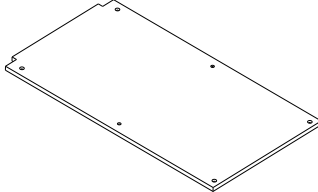
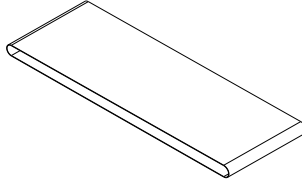
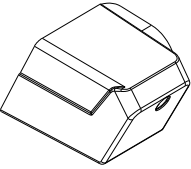
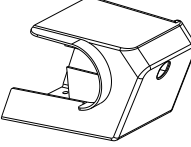
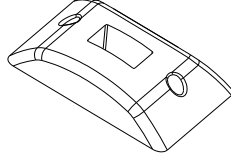
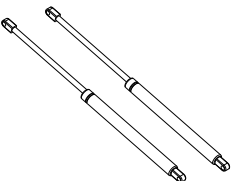
 <p>Front roller</p>	 <p>Rear roller</p>	 <p>Decorate rail</p>
 <p>Side rail</p>	 <p>Motor cover</p>	 <p>Console</p>
 <p>Handle bar</p>	 <p>Base cover</p>	 <p>Motor</p>
 <p>Incline motor</p>	 <p>Running board</p>	 <p>Running belt</p>
 <p>End cover (left)</p>	 <p>End cover (right)</p>	 <p>Feet</p>
 <p>Soft drop</p>		

ASSEMBLY DIAGRAM:

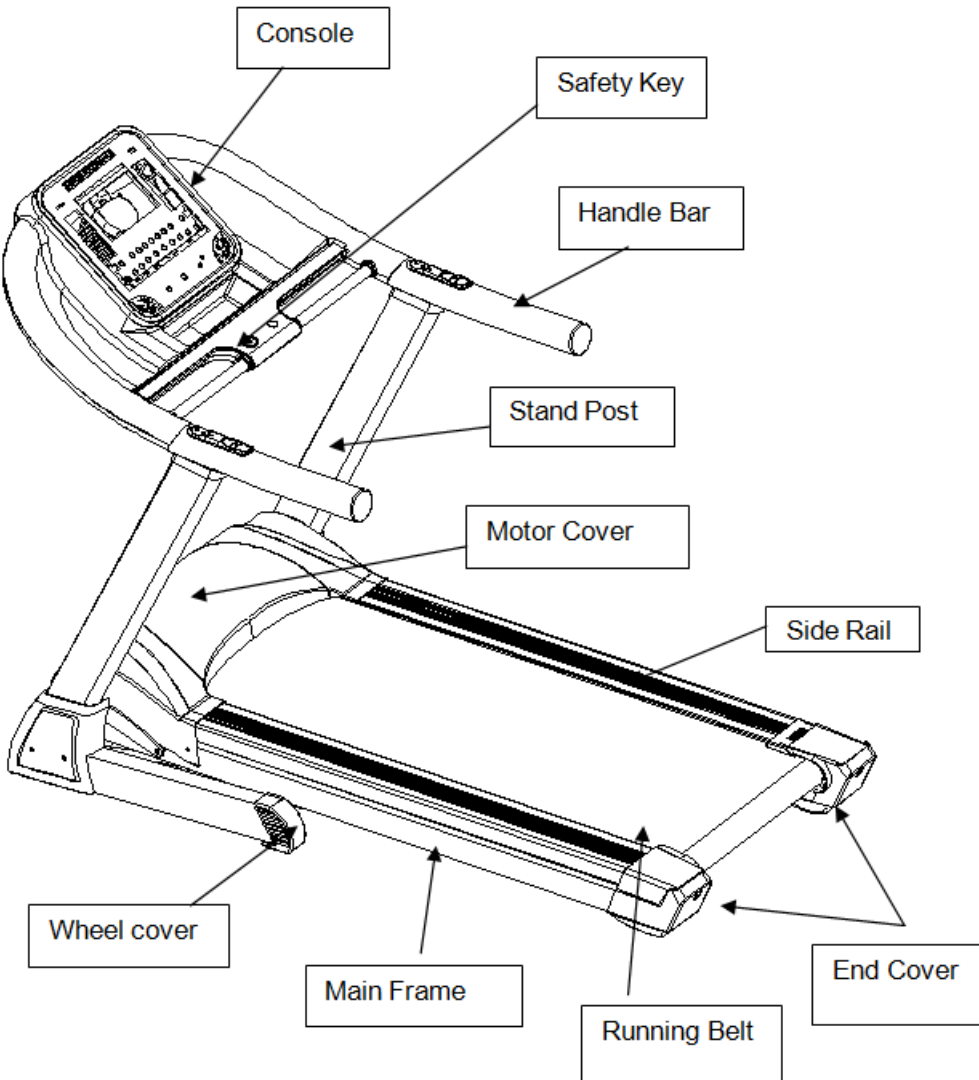

ASSEMBLY INSTRUCTIONS:

Step 1: Take the machine out of package, put on a flat surface; Use 4pcs M8*15 and 6pcs M8*55*20 screws separately to fit the stand post (left and right) onto the base frame.

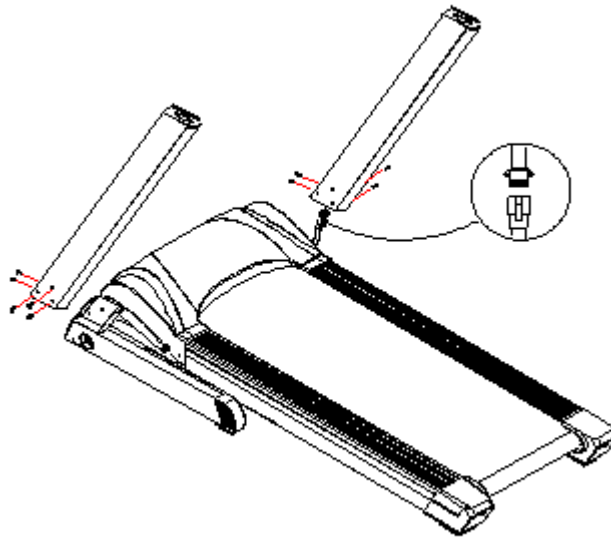

Step 2: Put the stand post cover on left and right stand post, and then use 4 pcs M4*20 screw to tight the stand post cover.

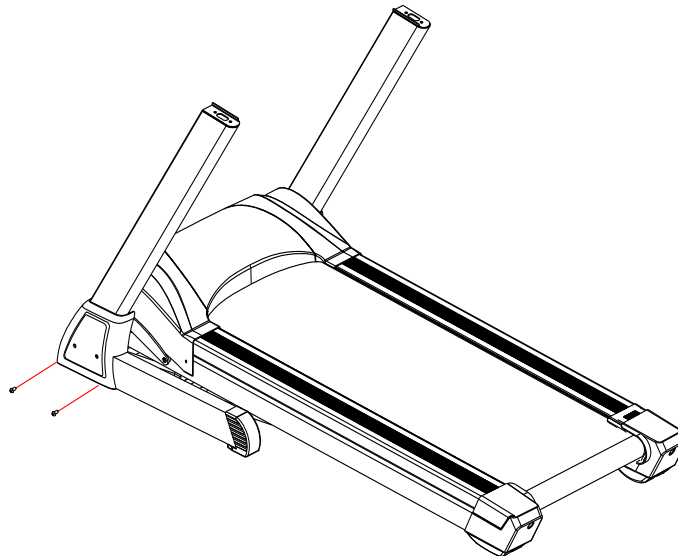

Step 3: Use 4 pcs M8*50*20 screws fit the console to the stand post and tight the screw.

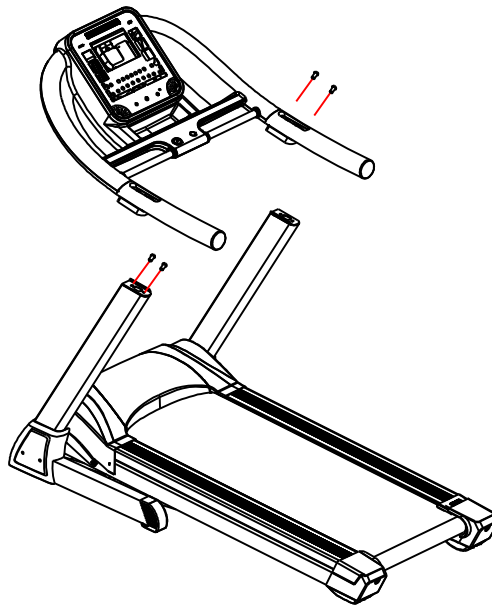

Step 4: Use 4pcs M3*28 screws fit the handle bar cover to the PU handle bar and tight the screw.

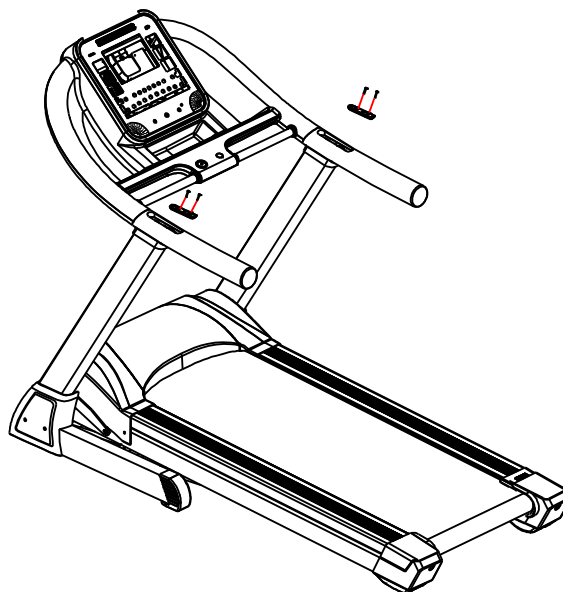

SETTING UP YOUR TREADMILL

FOLDING & UNFOLDING THE TREADMILL

1. Unplug from power point before folding
2. Lift deck until it's parallel to the upright post
3. Check the cylinder locks into right position
4. Place both hands on the running deck, and press one foot on the middle section of the cylinder to disengage the locking mechanism. Both hands press down, and the base frame can down slowly. Then take off both hands, the deck can down itself.

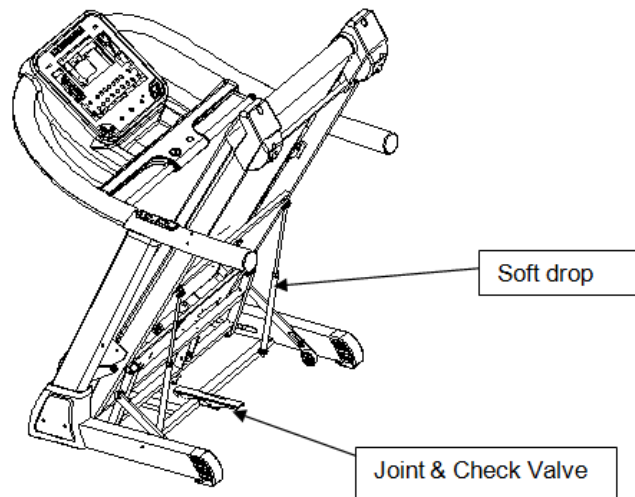

MOVING THE TREADMILL

1. Before moving, make sure the power is off.
2. Make sure the plug has pulled off.
3. Make sure the running base has been folded
4. The treadmill can be moved around in house safely in its fold-up position by using the transport wheels. Firmly hold onto handle bars with both hands, pull the treadmill towards you, incline 30-40 degree until it's portable on wheels, drag or push slowly.

SPECIAL SAFETY PRECAUTIONS

POWER SOURCE

- Choose a place in reach of a socket when placing the treadmill.
- Always connect the appliance to a socket with a grounded circuit and no other appliances connected to it. It is recommended not to use any extension cords.
- A faulty grounding of the appliance can cause the risk of electrical shocks. Ask a qualified electrician to check the socket in case you do not know if the appliance is grounded appropriately. do not modify the plug provided with the appliance if it is not compatible with your socket. ask a qualified electrician to install a suitable socket.
- Sudden voltage fluctuations can seriously damage the treadmill. Weather changes or switching on and off other appliances can cause peak voltages, over-voltage or interference voltage. To limit the danger of damage to the treadmill, it should be equipped with an over-voltage protective device (not included).
- Keep power cord away from the carrying roller. Do not leave the power cord below the striding belt. Do not use the treadmill with a damaged or worn out power cord.
- Unplug before cleaning or engaging in maintenance work. Maintenance should only be done by authorized service technicians, unless otherwise stated by the manufacturer. Ignoring those instructions would automatically void the warranty.
- Inspect the treadmill before every use to make sure that every part is operational.
- Do not use the treadmill outdoors, in a garage or under any kind of canopy. Do not expose the treadmill to high humidity or direct sunlight.
- Never leave the treadmill unattended.
- Make sure the striding belt is always tense. Start the striding belt before stepping on it.

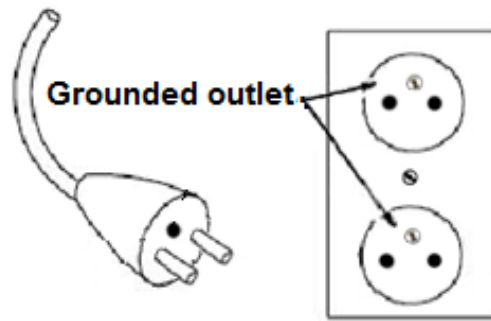

GENERAL FUNCTIONALITIES

- To start any workout phase after the setup, the user has to press the Start key.
- If the user presses the Stop key during the workout phase, the workout pauses.
- If the user presses the Stop key twice, the workout terminates and the system will return to the initial state.
- The Quick keys, Incline adjusting keys, Speed adjusting keys, and Start key only work during the workout period. These keys do not work during the setup stage.
- Program key and Mode key only work during the setup stage. The user may use these keys to choose their desired workout program and confirm the setting. These keys do not work during the workout phase.
- Hand pulse in front of the user will read the user's heart rate when both keypads are held properly.
- Pull out the safe key will stop the treadmill immediately.

CONSOLE

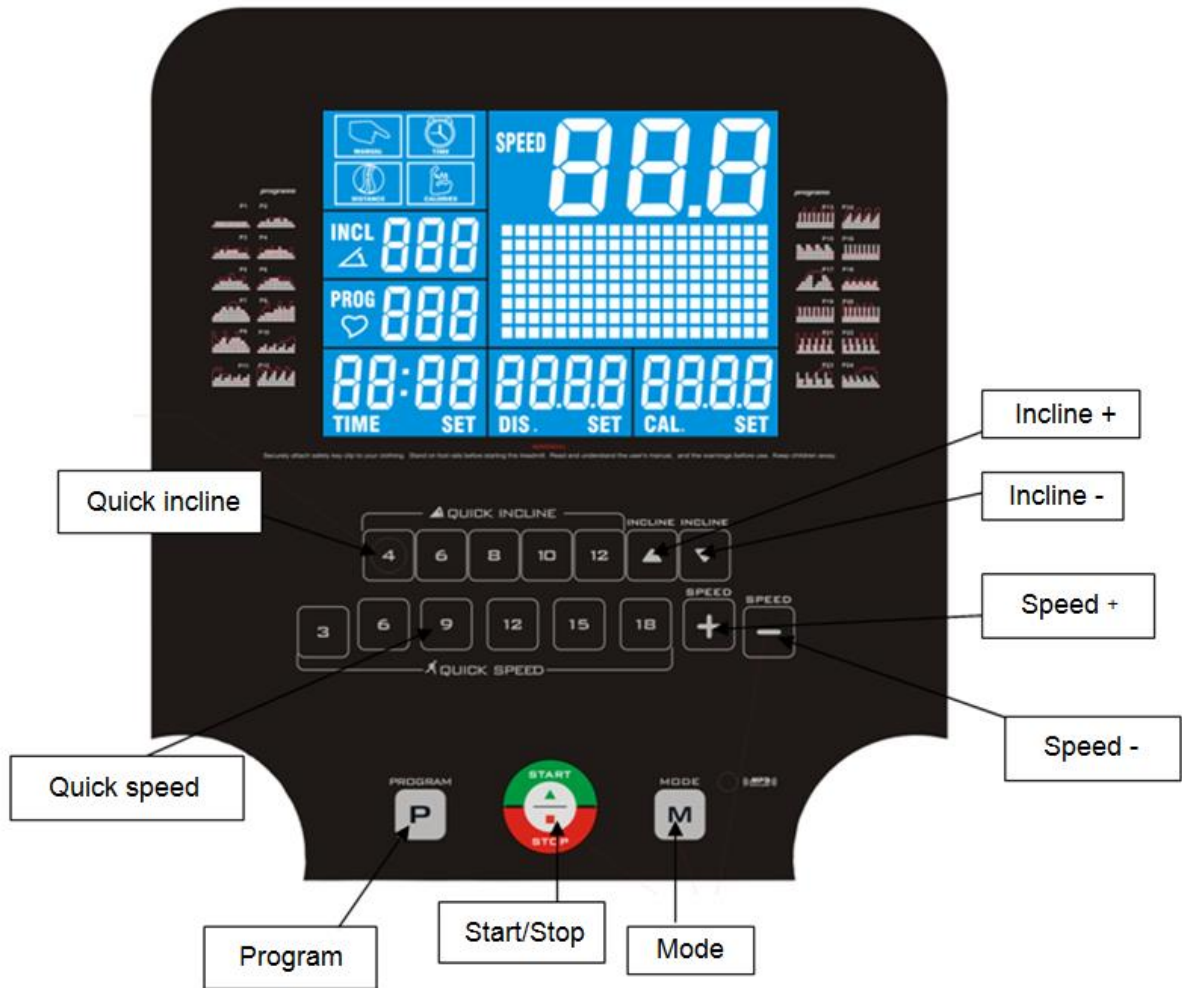

START THE TREADMILL:

When the treadmill connects to power, the LCD show like the below picture 1:

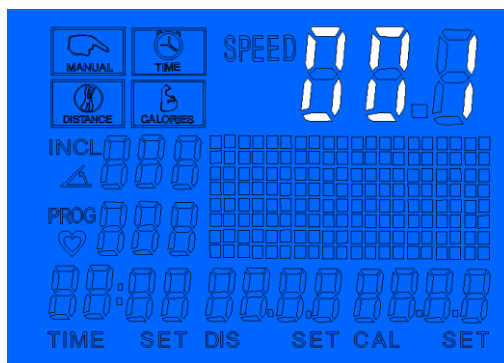

If the treadmill without the safety key, the LCD will show like the below picture 2:

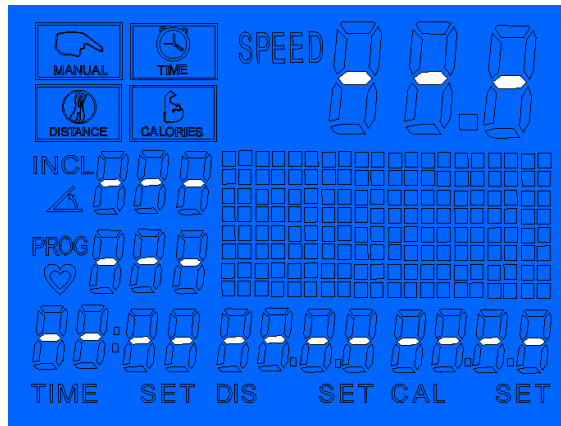

With the safety key, will show like below picture 3:

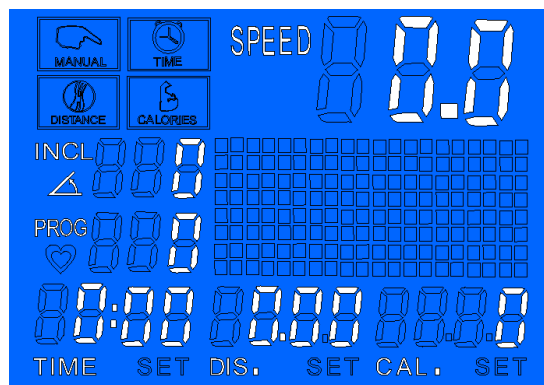

LCD WINDOW DISPLAY:

10" LCD window displays the item and number. Program and Pulse use the same window; if no pulse signal neither in Program, this window shows "P", in Program, it shows program number, if has pulse, it shows the pulse number.

In the picture 3: TIME window shows time; Cal window shows calorie; INCL shows incline number; PROG is program; DIS is distance; SPEED is speed number;  is pulse. When the treadmill paused, the **PROG** shows 24 program P0-P24-P0, and the window shows the profile, lasting for 3 seconds.

KEY INFORMATION:

1. Safety Key

A) Emergency STOP

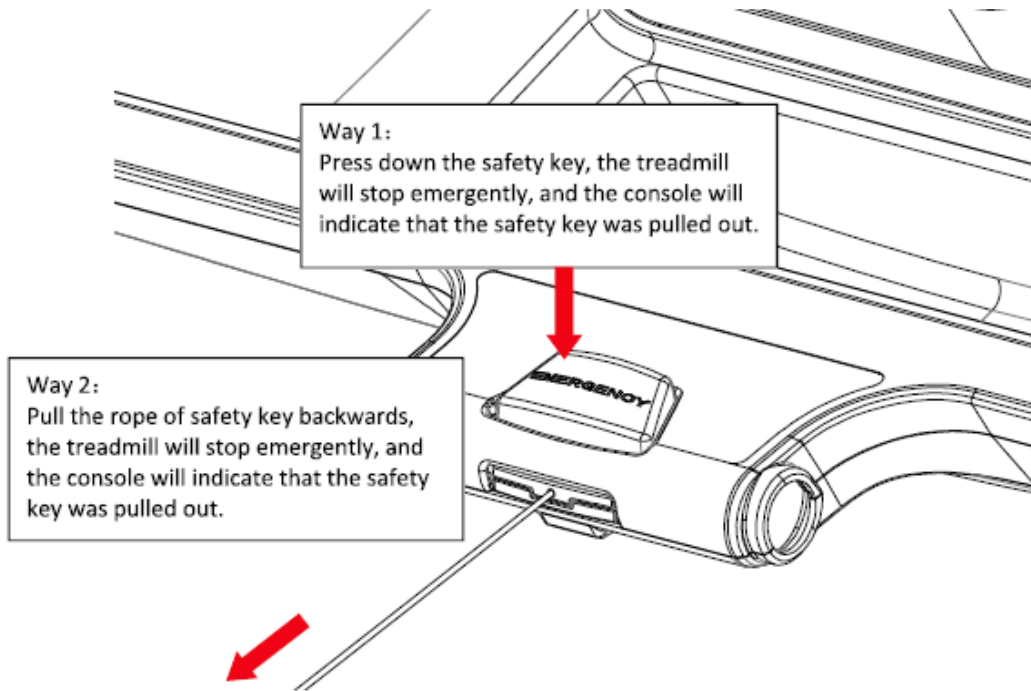

B) Safety key RESET

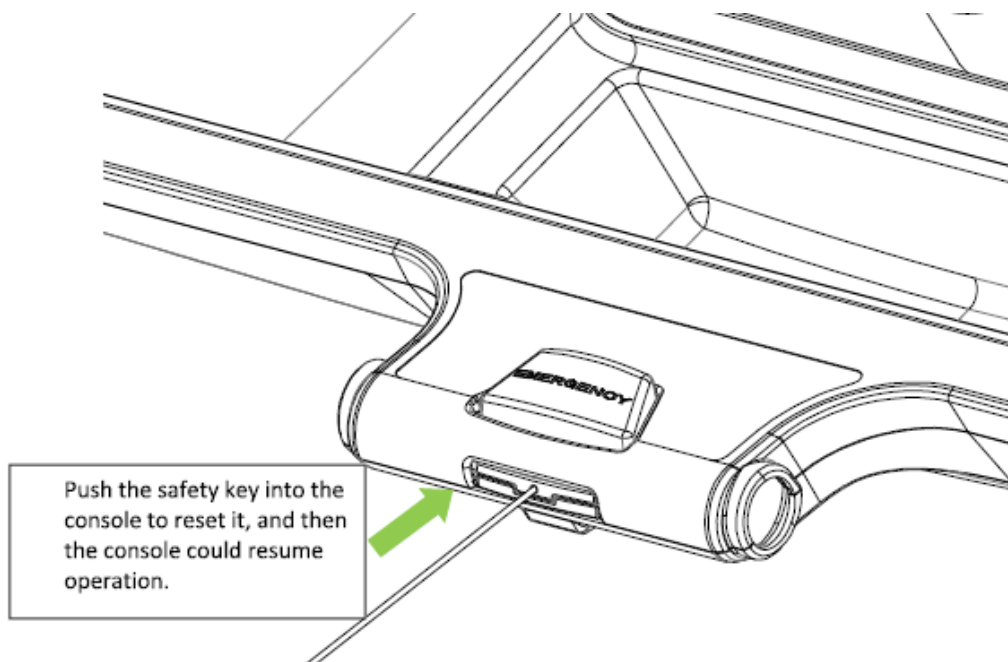

2. PROGRAM key:

Press the P key, program key: it will show:

0 → P-1 → P-2 → P-3 → P-4 → P-5 → P-6 → P-7 → P-8
↑ ↓
HRC ← FAT ← P24 ← ← P-10 ← P-9

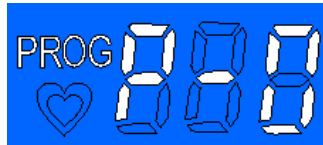

P0 is user's program, in this program, press "MODE" key, you can set three count-down program: TIME COUNT DOWN mode; DISTANCE COUNT DOWN mode; CALORIES COUNT DOWN mode.

Time 30:00 → Distance 1.00 → Calories 50

3. SPEED +/- key:

In the P1-P24 program, press Speed +/- key can adjust the time

4. BODY FAT function:

Press "PROG", choose "FAT" function, press" SPEED +/-" to adjust the item, press "MODE" to choose the item.

After setting the item, the LCD show "FAT", put two hands on the handle pulse key on the handle bar. After 3 seconds, it will show the result.

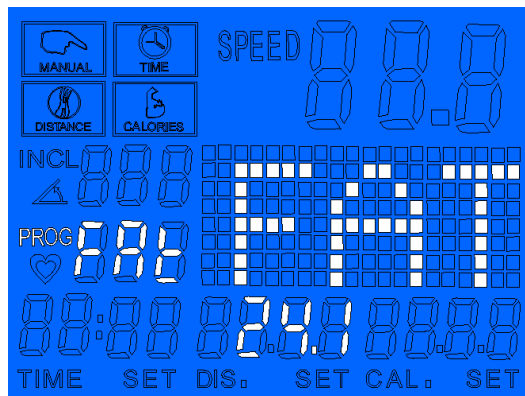

"01" shows the gender is male, "02" shows the gender is female

ITEM	Designed original number	Designed range
Age	25	10-99
Height	170CM	100-220
Weight	70KG	20-150

According to the standard of human being, the fat low 19 shows you are tend to be thin, it is perfect when the fat is between 20 to 25. If between 26 to 29 it suggests you are a little fat. If exceeds 30, it means you should lose weight.

5. START/STOP key:

In P0-P24, first time press START/STOP key , the window will show "3, 2, 1, Go" and with the buzzer sound "BI, and start the treadmill.

In countdown function, after choose press START/STOP key, the item begin the countdown function.

After choosing the program, press START/STOP key, then will start this program.

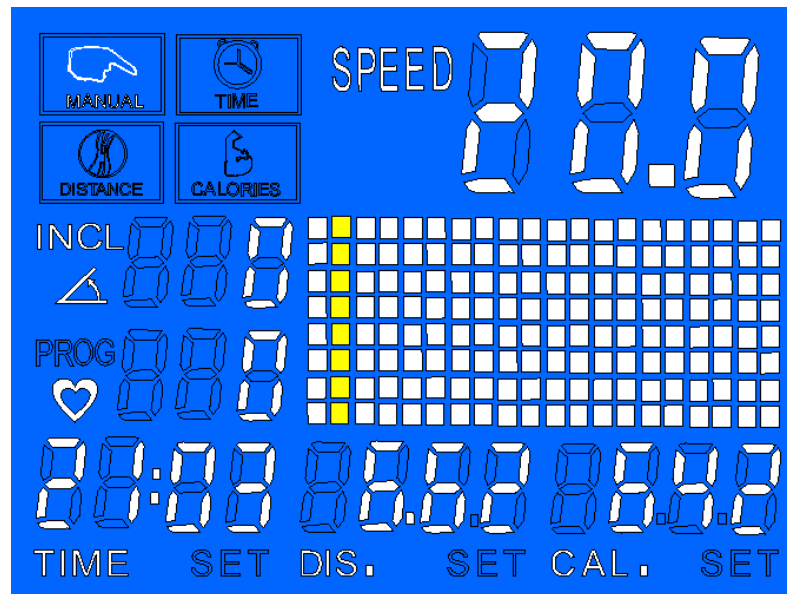

6. INCLINE +/- key:

Press Incline+/- key can increase and decrease the incline number.

In FAT function, press Incline+/- key, can adjust the item number.

7. SPEED +/- key:

Increase and decrease the speed, 0.1KM once.

In P0-P24, choose time, press Speed+/- key, can adjust the number.

In FAT, after choosing the item, press Speed+/- key can adjust the number.

8. Quick incline keys

9. Quick speed keys

WARNING! A system for monitoring heart rate may not be accurate. Overloading during training may cause serious injury or death. If you feel any discomfort, immediately stop the exercise!

Program speed diagram:

Program		Time Interval															
		1	2	3	4	5	6	7	8	9	10	11	12	13	14	15	16
P1	SPEED	2	3	3	4	4	4	4	4	4	4	4	4	4	3	3	2
	INCLINE	1	1	2	2	2	3	3	2	2	3	2	3	2	2	1	1
P2	SPEED	2	3	4	4	7	4	7	7	7	4	7	7	4	4	3	2
	INCLINE	2	3	4	3	4	4	5	5	6	7	6	6	5	4	3	2
P3	SPEED	2	3	4	4	7	7	4	7	7	7	7	4	4	4	3	2
	INCLINE	3	7	4	4	7	4	8	4	3	7	3	7	5	4	7	3
P4	SPEED	2	3	3	6	6	6	6	6	6	9	6	6	6	3	3	2
	INCLINE	3	7	4	4	7	4	8	4	3	7	3	7	5	4	7	2
P5	SPEED	2	3	4	6	6	6	6	9	6	6	6	6	6	4	3	2
	INCLINE	2	4	6	8	6	8	5	10	11	8	6	7	6	8	4	2
P6	SPEED	2	4	4	6	6	9	9	9	9	6	6	6	6	6	4	2
	INCLINE	3	4	5	6	5	6	5	7	6	7	5	7	6	7	7	3
P7	SPEED	4	6	6	9	11	11	9	11	11	9	11	11	9	9	6	4
	INCLINE	2	4	4	6	7	8	10	12	13	13	12	10	8	6	4	2
P8	SPEED	2	4	4	7	7	7	7	9	9	11	9	11	9	9	11	11
	INCLINE	2	4	8	10	13	2	4	8	10	13	2	4	9	10	13	2
P9	SPEED	3	6	6	9	11	11	7	9	11	11	11	11	9	9	6	3
	INCLINE	13	10	8	4	2	13	10	8	4	2	13	10	8	4	3	3
P10	SPEED	2	4	4	6	2	4	4	6	2	4	4	6	2	4	4	6
	INCLINE	2	2	4	4	3	4	5	6	5	6	8	7	8	9	10	10
P11	SPEED	4	6	6	9	4	6	6	9	4	6	6	9	4	6	6	9
	INCLINE	10	12	10	12	8	8	7	7	5	6	5	6	4	3	4	3
P12	SPEED	3	6	9	11	3	6	9	11	3	6	9	11	3	6	9	11
	INCLINE	12	11	9	8	12	11	9	8	12	11	9	8	12	11	9	8
P13	SPEED	4	12	4	12	4	12	4	12	4	12	4	12	4	12	4	12
	INCLINE	4	8	10	12	4	8	10	12	4	8	10	12	4	8	10	12
P14	SPEED	3	6	9	11	3	6	9	11	3	6	9	11	3	6	9	11
	INCLINE	4	8	10	12	4	8	10	12	4	8	10	12	4	8	10	12
P15	SPEED	11	11	9	6	11	11	9	6	11	11	9	6	11	11	9	6
	INCLINE	2	3	4	5	6	8	7	8	8	7	7	6	5	4	3	2
P16	SPEED	4	12	4	12	4	12	4	12	4	12	4	12	4	12	4	12
	INCLINE	2	4	5	6	2	4	5	6	2	4	5	6	2	4	5	6
P17	SPEED	2	4	6	6	9	11	11	2	4	6	6	11	11	9	6	2
	INCLINE	2	4	6	8	10	12	13	12	13	12	13	10	8	6	4	2

P18	SPEED	3	6	6	3	6	6	3	6	6	3	6	6	3	6	6	2
	INCLINE	2	6	8	2	6	8	2	6	8	2	6	8	2	6	8	2
P19	SPEED	4	12	4	12	4	12	4	12	4	12	4	12	4	12	4	12
	INCLINE	10	8	6	4	10	8	6	4	10	8	6	4	10	8	6	4
P20	SPEED	4	12	4	12	4	12	4	12	4	12	4	12	4	12	4	12
	INCLINE	12	8	2	12	8	2	12	8	2	12	8	2	12	8	2	2
P21	SPEED	2	6	11	2	6	11	2	6	11	2	6	11	2	6	11	2
	INCLINE	12	8	2	12	8	2	12	8	2	12	8	2	12	8	2	2
P22	SPEED	11	6	2	11	6	2	11	6	2	11	6	2	11	6	2	2
	INCLINE	2	4	10	2	4	10	2	6	12	6	8	12	6	8	12	2
P23	SPEED	11	6	6	2	11	6	6	2	11	6	6	2	11	6	6	2
	INCLINE	2	3	4	5	6	6	7	8	10	11	12	12	13	13	10	2
P24	SPEED	11	6	4	11	6	4	11	6	4	11	6	4	11	6	4	2
	INCLINE	4	4	5	6	7	8	10	10	12	13	12	13	12	13	10	2

ERROR MESSAGE AND SOLUTIONS

SYMPTOM	DESCRIPTION	SOLUTION
E01	Console is bad	Control board is bad, cannot start the treadmill. Console show the E01, warning sound 3times. Solution: console and control board connect not well, check the connection wire set between the console and control board. If connection is bad, change the wire.
E02	The motor wire is bad.	Treadmill cannot start, warning sound 9times. Console show the E02. If treadmill can restart, it will be ok. Solution: check the motor wire, and reconnect. If the control board smells bad, change the control board.
E03	No speed sensor signal: control board has send the signal to motor, but cannot receive the signal from motor for 3seconds.	Treadmill cannot start, warning sound 9times. Console show the E03. If treadmill can restart in 10 seconds, it will be ok. Solution: No speed sensor signal for 3seconds, then check the sensor plug or change the speed sensor.
E04	Incline motor learn by itself	Check the incline motor wire, and wire connections. Check the AC wire on incline motor and the connection to control board. Change the wire or incline motor. Then press the key to let the incline motor learn by itself.

E05	Over current protection: treadmill is running, control board check the current is over standard current +6A for 3 seconds	Treadmill cannot start, warning sound 9times. Console show the E05. If treadmill can restart in 10 seconds, it will be ok. Solution: current is over the standard current, so system take protection. Or some part cannot work; causing the motor cannot run normally. Recheck the treadmill, and restart the treadmill. Check if the bad smell, change motor, or control board has. Recheck the current is right or not.
E06	Over explosion protection: voltage is not correct or motor not work well, cause motor wire bad.	Treadmill cannot start, warning sound 9times. Console show the E06. If treadmill can restart, it will be ok. Solution: check the voltage is lower than 10% standard voltage, using the correct voltage to check again. Check control board smelling, if burnt smell, change control board. Check the motor wire connection, reconnect.

TREADMILL MAINTENANCE

Proper maintenance is very important to ensure a faultless and operational condition of the treadmill. Improper maintenance can cause damage to the treadmill or shorten the life of the product.

All parts of the treadmill must be checked and tightened regularly. Worn out parts must be replaced immediately.

1. Lubrication:

The treadmill is factory-lubricated. However, it is recommended to check the lubrication of the treadmill regularly, to ensure an optimal operation of the treadmill. It is usually not necessary to lubricate the treadmill in the first year or the first 500 hours of operation.

After every 3 months of operation, lift the sides of the treadmill and feel the surface of the belt, as far as possible. If traces of silicon spray are found, lubrication is not necessary.

In case of a dry surface refer to the following instructions.

Only use oil free silicon spray.

2. Application of lubricant on the belt:

- Position the belt so that the seam is located in the middle of the plate.
- Insert the spray valve in the spray head of the lubricant container.
- Lift the belt at one side and hold the spray valve in a distance to the front end of striding belt and plate. Start at the front end of the belt. Lead the spray valve in direction of the back end. Repeat this process on the other side of the belt. Spray each side for about 4 seconds.
- Wait 1 minute to let the silicon spray spread, before starting the machine.

3. Cleaning:

Regular cleaning of the striding belt ensures a long product life.

- Warning: The treadmill must be turned off to avoid electrical shocks. The power cord must be pulled out of the socket, before starting the cleaning or maintenance.
- After each training: Wipe the console and other surfaces with a clean soft and damp cloth to remove sweat residues.
- Caution: Do not use any abrasives or solvents. To avoid damage to the computer, keep any liquids away. Do not expose the computer to direct sunlight.

- Weekly: To make the cleaning easier it is recommended to use a mat for the treadmill. Shoes can leave dirt on the striding belt that can fall beneath the treadmill. Clean the mat under the treadmill once a week.

4. Belt adjustment

You may need to adjust the running belt during the first few weeks of use. All running belts are properly set at the factory. It may stretch or be off center after use. Stretching is normal during the break-in period.

Adjusting the belt tension:

If the running belt feels as though it is —slipping or hesitating when you plant your foot during a run, the tension on the running belt may have to be increased.

TO INCREASE THE RUNNING BELT TENSION:

- Place 8mm wrench on the left belt tension bolt. Turn the wrench clockwise 1/4 turn to draw the rear roller and increase the belt tension.
- Repeat STEP 1 for the right belt tension bolt. You must be sure to turn both bolts the same number of turns, so the rear roller will stay square relative to the frame.
- Repeat STEP 1 and STEP 2 until the slipping is eliminated.
- Be careful not to tighten the running belt tension too much as you can create excessive pressure on the front and rear roller bearings. An excessively tightened running belt may damage the roller bearings that would result in bearing noise from the front and rear rollers.

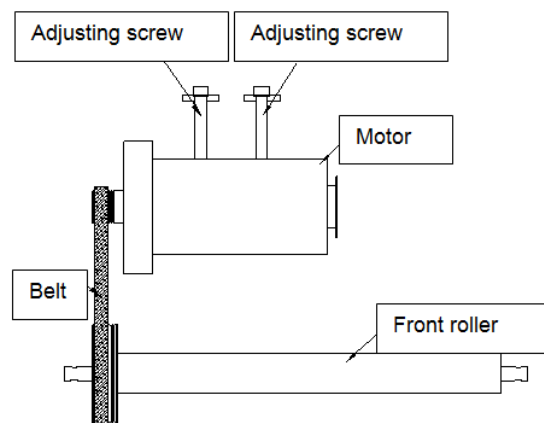

TO DECREASE THE TENSION ON THE RUNNING BELT, TURN BOTH BOLTS COUNTER-CLOCKWISE THE SAME NUMBER OF TURNS.

Centering the running belt

When you run, you may push off harder with one foot than with another. **The severity of the deflection depends on the amount of force that one foot exerts in the relation to the other.** This deflection can cause the belt to move off- centre. **This deflection is normal and the running belt will centre when nobody is on the running belt.** If the running belt remains consistently off-centre, you will need to centre the running belt manually.

Start the treadmill without anyone on the running belt, press FAST-key until speed reached 6kph.

- Observe whether the running belt is toward the right or left side of the deck.
 - If toward the left side of the deck, using wrench, turn the left adjustment bolt clockwise 1/4 turn and the left adjustment bolt counter clockwise 1/4.
 - If toward the right side of the deck, turn the right adjustment bolt clockwise 1/4 turn and the left adjustment bolt counter clockwise 1/4.
 - If the belt is still not centre, repeat the above step until the running belt is on centre.
- After the belt is centre, increase the speed to 16kph and verify that it is running smoothly. Repeat the above steps if it is necessary.

If the above procedure is unsuccessful in resolving the off-centre, you may need to increase the belt tension.

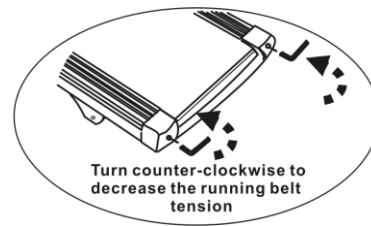
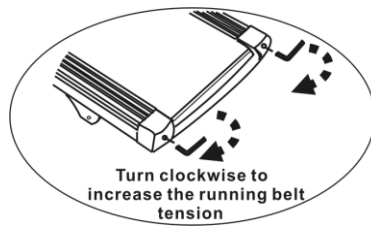

5. Storage

Store your treadmill in a clean and dry environment. Ensure the master power switch is off and is un-plugged from the electrical wall outlet.

6. Important notes

- The device corresponds to current safety standards. The device is only suitable for home use. Any other use is impermissible and possibly even dangerous. We cannot be held liable for damages that were caused by improper usage.
- Please consult your GP before starting your exercise session to clarify whether you are in suitable physical health for exercising with this device. The doctor's diagnosis should be the basis for the structure of your exercise program. Incorrect or excessive training could be harmful to your health.
- Carefully read through the following general fitness tips and the exercise instructions. If you have pain, shortness of breath, feel unwell or have other physical complaints, break off the exercise immediately. Consult a doctor immediately if you have prolonged pain.
- This fitness device is not suitable for professional or medical use, nor may it be used for therapeutic purposes.
- The pulse sensor is not a medical device. It is meant for your information purposes only and is designed to give an average pulse rate. It is not intended to offer medical advice nor will it measure pulse accurately every time, due to differing environmental and human conditioning factors.

EXPLODED DRAWING

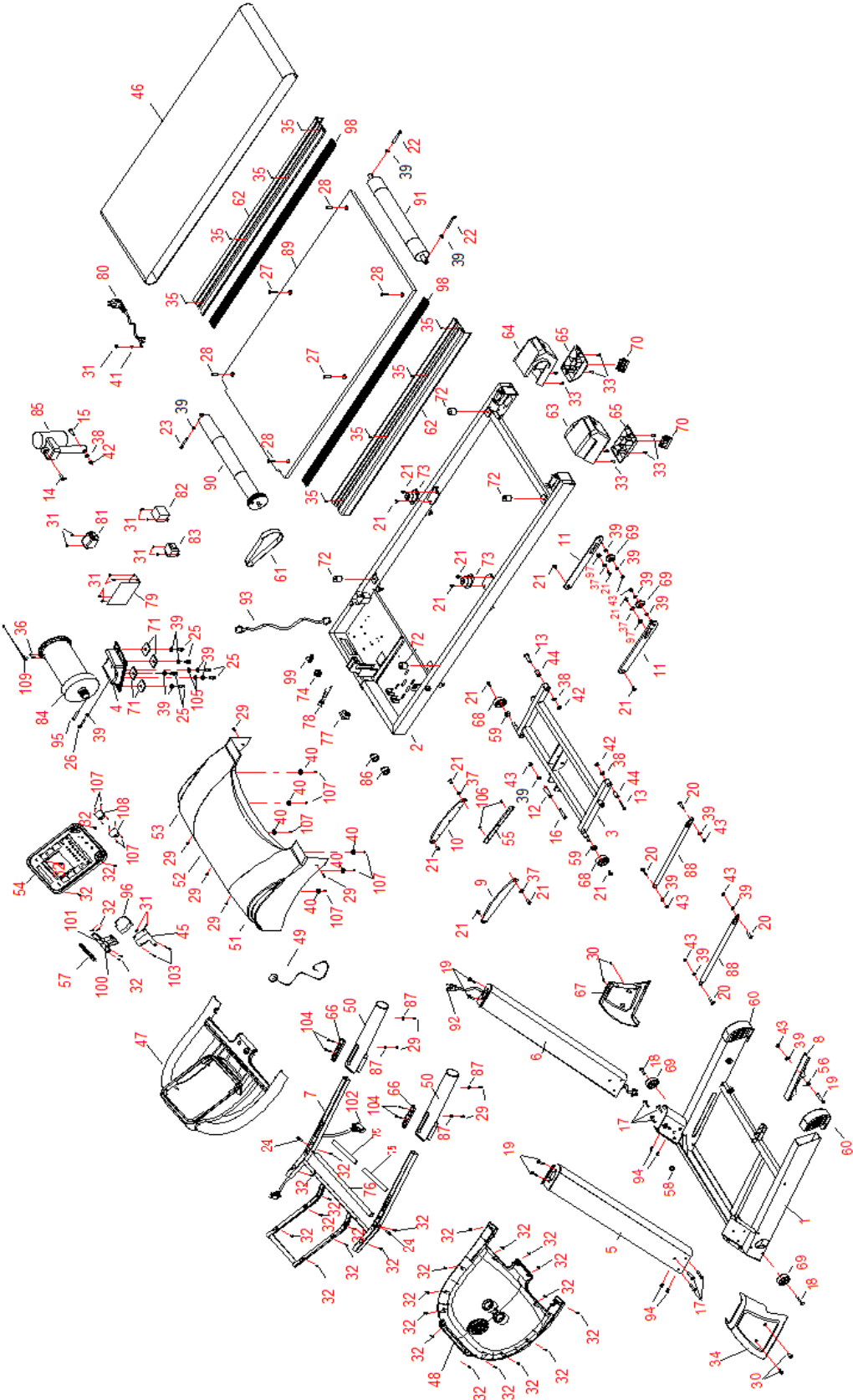

PARTS LIST

NO	DESCRIPTION	QUANTITY
1	Base fame	1
2	Platform frame	1
3	Incline frame	1
4	Motor base frame	1
5	Left Upright frame	1
6	Right Upright frame	1
7	Computer frame	1
8	Ezfit linking parts	1
9	Connecting sheet left	1
10	Connecting sheet right	1
11	Wheel cover frame	2
12	Limited tube	1
13	Inner hex half thread screw M10*50	2
14	Inner hex half thread screw M10*35	1
15	Inner hex full thread screw M10*60	1
16	Inner hex half thread screwM8*80	1
17	Cross Allen full thread screw ST4*45	2
18	Inner hex half thread screw M8*60	8
19	Inner hex half thread screwM8*50	1
20	Inner hex half thread screw M8*30	6
21	Inner hex full thread screw M8*10	14
22	Allen socket full thread screw M8*75	2
23	Allen socket full thread screw M8*65	1
24	Allen socket full thread screw M8*30	2
25	Allen socket full thread screw M8*20	8
26	Hex full thread screw M8*40	2
27	Philip full thread screw M8*25	2
28	Philip full thread screw M6*25	4
29	Cross Allen full thread screw M5*20	4
30	Cross Allen full thread screw M5*10	15
31	Cross Allen full thread screw M4*10	11
32	Cross Allen full thread screw ST4*15	32
33	Cross Allen full thread screw ST4*10	4
34	Base frame cover left	1
35	Philip full thread screw M8*25	8

36	Philip full thread screw M8*25	2
37	Washer $\Phi 25 \times \Phi 8.2 \times 2$	4
38	Washer $\Phi 10$	2
39	Washer $\Phi 8$	24
40	Washer $\Phi 6 \times \Phi 20$	6
41	Washer $\Phi 5$	1
42	Washer M10	2
43	Washer M8	10
44	Metal plug $\Phi 17 \times \Phi 10 \times 31$	2
45	Fan washer	1
46	Running belt	1
47	Computer up cover	1
48	Computer down cover	1
49	Safety key	1
50	Hand bar cover	2
51	Motor cover - left	1
52	Motor cover - center	1
53	Motor cover - right	1
54	PCB board	1
55	Wire protector	1
56	Spring	1
57	Fan	1
58	Wire cover	1
59	Washer	2
60	Feet cover	2
61	Belt	1
62	Side rail	2
63	End cover left	1
64	End cover right	1
65	End cover feet	2
66	Handle pulse	4
67	Base frame cover right	1
68	Wheel $\Phi 62 \times \Phi 12.5 \times t26$	2
69	Wheel $\Phi 63 \times \Phi 8.2 \times t26$	4
70	Wheel $\Phi 45 \times \Phi 8.5 \times t18$	4
71	Motor frame mat	4
72	Cushion for running board	4
73	Cushion for running board	2

74	Wire clip	1
75	Foam	2
76	Wire	8
77	Switch	1
78	Fuse	1
79	Controller	1
80	Power wire	1
81	Filter	1
82	Speed sensor	1
83	Transformer	1
84	Motor	1
85	Incline motor	1
86	Magnet ring $\Phi 33 \times \Phi 14 \times 33$	1
87	Magnet ring $\Phi 20 \times \Phi 9 \times 32$	1
88	Cylinder	2
89	Running board	1
90	Front roller	1
91	Rear roller	1
92	Wire in stand post	1
93	Wire to controller	1
94	Inner hex full thread screw M8*15	1
95	Screw M8*65	1
96	Fan	1
97	Tube plug $\Phi 19.5 \times \Phi 14.2 \times 8.5$	2
98	Decorate rail	2
99	Wire Clip	1
100	Air outlet left	1
101	Air outlet right	1
102	Wire	1
103	Ventilator holder screw	1
104	Screw M3x28	4
105	Washer	2
106	Screw	2
107	Screw	8
108	Bushing	4
109	Rev. counter	1

GENERAL FITNESS TIPS

Start your exercise program slowly, i.e. one exercise unit every 2 days. Increase your exercise session week by week. Begin with short periods per exercise and then increase these continually. Start slowly with the exercise sessions and don't set yourself impossible targets. In addition to these exercises, do other forms of exercise such as jogging, swimming, dancing and/or cycling.

Always warm up thoroughly before exercising. To do so, carry out at least five minutes of stretching or gymnastic exercises to avoid muscle strains and injuries.

Check your pulse regularly. If you do not have a pulse measuring instrument, ask your GP how you can measure your heart rate effectively. Determine your personal exercise frequency range to achieve optimal training success. Take into account both your age and your level of fitness. The following table will give you a reference point for determining the optimal exercise pulse:

Age	Heart rate frequency range 50-75% (beats per minute) - ideal training pulse -	Maximum heart rate frequency 100%
20 years	100-150	200
25 years	98-146	195
30 years	95-142	190
35 years	93-138	185
40 years	90-135	180
45 years	88-131	175
50 years	85-127	170
55 years	83-123	165
60 years	80-120	160
65 years	78-116	155
70 years	75-113	150

COPYRIGHT(c) 1997 AMERICAN HEART ASSOCIATION

(Your GP can give you more information on the current guidelines.)

Make sure you breathe regularly and calmly when exercising.

Take care to drink enough while exercising. This ensures that the liquid requirement of your body is satisfied. Consider that the recommended drinking amount of 2-3 liters per day is strongly increased through physical strain. The fluid you drink should be at room temperature.

When exercising on the device always wear light and comfortable clothing as well as sports shoes. Do not wear any loose clothing that could tear or become caught in the device whilst exercising.

WARM-UP / STRETCHING EXERCISES

A successful exercise session begins with warming up exercises and ends with exercises for cooling down and relaxing. These warming up exercises prepare your body for the subsequent demands made upon it. The cooling down / relaxation period after the exercise session ensures that you do not experience any muscular problems. In the following you will find stretching exercise instructions for warming up and cooling down. Please pay attention to the following points:

TOUCH TOES

Bend your trunk slowly forwards and try to touch your feet with your hands. Reach down as far as possible to your toes. Maintain this position for 20-30 seconds if possible



EXERCISES FOR THE KNEES

Sit on the floor and stretch out your right leg. Bend your left leg and place your foot on your right upper thigh. Now try to reach your right foot with your right arm. Maintain this position for 30-40 seconds if possible



EXERCISES FOR THE CALVES/ACHILLES TENDON

Place both hands on the wall and support your full body weight. Then move your left leg backwards and alternate it with your right leg. This stretches the back of the leg. Maintain this position for 30-40 seconds if possible.



EXERCISES FOR THE UPPER THIGH

Support yourself by placing your hand on the wall, then reach down behind you and lift up your right or left foot as close to your buttocks as possible. Feel a comfortable tension in your front upper thigh. Maintain this position for 30 seconds if possible and repeat this exercise 2 times for each leg



INSIDE UPPER THIGH

Sit on the floor and place your feet in such a way that your knees are facing outwards. Pull your feet as close as possible to your groin. Now press your knees carefully downwards. Maintain this position for 30-40 seconds if possible.



TERMS AND CONDITIONS OF WARRANTY, WARRANTY CLAIMS

General Conditions of Warranty and Definition of Terms

All Warranty Conditions stated hereunder determine Warranty Coverage and Warranty Claim Procedure. Conditions of Warranty and Warranty Claims are governed by Act No. 40/1964 Coll. Civil Code, Act No. 513/1991 Coll., Commercial Code, and Act No. 634/1992 Coll., Consumer Protection Act, as amended, also in cases that are not specified by these Warranty rules.

The seller is SEVEN SPORT s.r.o. with its registered office in Borivojova Street 35/878, Prague 13000, Company Registration Number: 26847264, registered in the Trade Register at Regional Court in Prague, Section C, Insert No. 116888.

According to valid legal regulations it depends whether the Buyer is the End Customer or not.

“The Buyer who is the End Customer” or simply the “End Customer” is the legal entity that does not conclude and execute the Contract in order to run or promote his own trade or business activities.

“The Buyer who is not the End Customer” is a Businessman that buys Goods or uses services for the purpose of using the Goods or services for his own business activities. The Buyer conforms to the General Purchase Agreement and business conditions to the extent specified in the Commercial Code.

These Conditions of Warranty and Warranty Claims are an integral part of every Purchase Agreement made between the Seller and the Buyer. All Warranty Conditions are valid and binding, unless otherwise specified in the Purchase Agreement, in the Amendment to this Contract or in another written agreement.

Warranty Conditions

Warranty Period

The Seller provides the Buyer a 24 months Warranty for Goods Quality, unless otherwise specified in the Certificate of Warranty, Invoice, Bill of Delivery or other documents related to the Goods. The legal warranty period provided to the Consumer is not affected.

By the Warranty for Goods Quality, the Seller guarantees that the delivered Goods shall be, for a certain period of time, suitable for regular or contracted use, and that the Goods shall maintain its regular or contracted features.

The Warranty does not cover defects resulting from (if applicable):

- User's fault, i.e. product damage caused by unqualified repair work, improper assembly, insufficient insertion of seat post into frame, insufficient tightening of pedals and cranks
- Improper maintenance
- Mechanical damages
- Regular use (e.g. wearing out of rubber and plastic parts, moving mechanisms, joints etc.)
- Unavoidable event, natural disaster
- Adjustments made by unqualified person
- Improper maintenance, improper placement, damages caused by low or high temperature, water, inappropriate pressure, shocks, intentional changes in design or construction etc.

Warranty Claim Procedure

The Buyer is obliged to check the Goods delivered by the Seller immediately after taking the responsibility for the Goods and its damages, i.e. immediately after its delivery. The Buyer must check the Goods so that he discovers all the defects that can be discovered by such check.

When making a Warranty Claim the Buyer is obliged, on request of the Seller, to prove the purchase and validity of the claim by the Invoice or Bill of Delivery that includes the product's serial number, or eventually by the documents without the serial number. If the Buyer does not prove the validity of the Warranty Claim by these documents, the Seller has the right to reject the Warranty Claim.

If the Buyer gives notice of a defect that is not covered by the Warranty (e.g. in the case that the Warranty Conditions were not fulfilled or in the case of reporting the defect by mistake etc.), the Seller is eligible to require a compensation for all the costs arising from the repair. The cost shall be calculated according to the valid price list of services and transport costs.

If the Seller finds out (by testing) that the product is not damaged, the Warranty Claim is not accepted. The Seller reserves the right to claim a compensation for costs arising from the false Warranty Claim.

In case the Buyer makes a claim about the Goods that is legally covered by the Warranty provided by the Seller, the Seller shall fix the reported defects by means of repair or by the exchange of the damaged part or product for a new one. Based on the agreement of the Buyer, the Seller has the right to exchange the defected Goods for a fully compatible Goods of the same or better technical characteristics. The Seller is entitled to choose the form of the Warranty Claim Procedures described in this paragraph.

The Seller shall settle the Warranty Claim within 30 days after the delivery of the defective Goods, unless a longer period has been agreed upon. The day when the repaired or exchanged Goods is handed over to the Buyer is considered to be the day of the Warranty Claim settlement. When the Seller is not able to settle the Warranty Claim within the agreed period due to the specific nature of the Goods defect, he and the Buyer shall make an agreement about an alternative solution. In case such agreement is not made, the Seller is obliged to provide the Buyer with a financial compensation in the form of a refund.



SEVEN SPORT s.r.o.

Registered Office:

Borivojova 35/878, 130 00 Praha 3, Czech Republic

Headquarters: Delnicka 957, 749 01 Vitkov, Czech Republic
Warranty & Service Centre: Cermenska 486, 749 01 Vitkov, Czech Republic
CRN: 26847264
VAT ID: CZ26847264
Phone: +420 556 300 970
E-mail: eshop@insportline.cz
reklamace@insportline.cz
servis@insportline.cz
Web: www.insportline.cz

SK

INSPORTLINE s.r.o.

Headquarters, Warranty & Service centre: Elektricka 6471, 911 01 Trencin, Slovakia
CRN: 36311723
VAT ID: SK2020177082
Phone: +421(0)326 526 701
E-mail: objednavky@insportline.sk
reklamacie@insportline.sk
servis@insportline.sk
Web: www.insportline.sk

Date of Sale:

Stamp and Signature of Seller: